

Galaxy V Series

Installation and Operation Manual

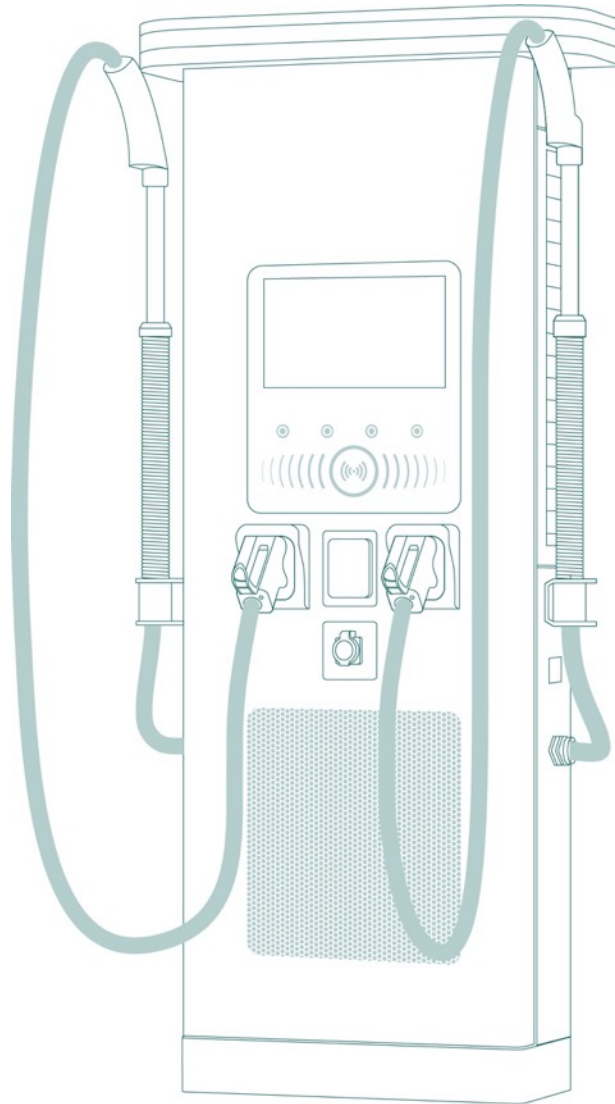

50/60/80 kW

Public operation charging station

Important Safety Information

To ensure safe operation and full understanding of all product functions, read this manual carefully before using the product. Keep this manual in a readily accessible location near the equipment for future reference whenever operational guidance is required.

Disclaimer of Warranties and Limitation of Liabilities

All information contained in this manual is based on the latest available data at the time of publication. RAEDIAN reserves the right to modify the contents of this manual without prior notice. Although every effort has been made to ensure accuracy, no guarantee is given regarding completeness or correctness, including but not limited to product specifications, functions, and illustrations. RAEDIAN shall not be held liable for any damage, loss, or cost arising from failure to comply with this manual or applicable standards and regulations. Failure to strictly follow the instructions will immediately void any applicable warranty. Any unauthorized modification, manipulation, or alteration — whether hardware or software — shall result in immediate termination of the warranty.

Copyright Notice

Company names and model designations mentioned in this manual may be trademarks or registered trademarks of their respective owners. All content is the intellectual property of RAEDIAN New Energy Technology Corp., Ltd. ("RAEDIAN®") and is protected by copyright law. All rights reserved. No part of this manual may be reproduced, stored, or transmitted in any form or by any means without prior written permission from RAEDIAN.

Support

Web: www.raedian.com

Email: support@raedian.com

For support in other markets, please get in touch with your local representative.

Conventions Used in this Manual

Dangers, Warnings, and Caution

Level	Description
DANGER	Indicates an imminently hazardous situation which, if not avoided, will result in death or serious injury.
WARNING	Indicates a potentially hazardous situation which, if not avoided, could result in death or serious injury.
CAUTION	Indicates a potentially hazardous situation which, if not avoided, may result in minor or moderate injury.
NOTE	Provides additional information such as explanations and tips.

Bold Text is used to highlight selectable items such as buttons and menu options.

Content

1. General	5	4.3.2 Residual Current Device (RCD) Protection	23
1.1 Introduction	5	4.4 Preparing for Commissioning	23
1.2 Intended Use	5	4.4.1 Site readiness requirements	23
1.3 Overview	6	4.4.2 Required information	24
1.3.1 Outside View	6	4.4.3 Power energization support	24
1.3.2 Inside View	7		
1.3.3 Cable Management System	8	5. Operation	25
1.3.4 Working Principal Diagram	9	5.1 Before Use	25
1.4 Symbols	10	5.2 Charging Procedure	26
1.5 Terminology	11	5.2.1 Screen Layout	26
		5.2.2 Authorization	27
2. Safety Information	12	5.2.3 Start Charging	27
2.1 Liability	12	5.2.4 Charging	28
2.1.1 Installation Engineer Qualifications	12	5.2.6 Finish Charging	29
2.1.2 Responsibilities and Qualifications for Users	12	5.3 Charging Errors	29
2.2 Precautions for Use	12	5.4 Energizing the Galaxy V Series	29
2.2.1 Transportation	12	5.5 De-energizing the Galaxy V Series	29
2.2.2 Installation	12	5.5.1 Measuring AC Voltage	29
2.2.3 Operation	12	5.5.2 Measuring DC Voltage	29
2.2.4 Maintenance	12		
2.2.5 Disposal	12	6. Maintenance	30
2.3 Personal Protective Equipment	13	6.1 Maintenance Schedule	30
2.4 Cyber Security	13	6.2 Cleaning	30
		6.3 Preventive Maintenance	30
3. Preparation	14		
3.1 Before Installation	14	7. Troubleshooting	32
3.2 Location Requirements	14	7.1 General Troubleshooting	32
3.3 Unpacking	16	7.2 Service Troubleshooting	33
3.3.1 Forklift truck / Wheel loader pallet fork	16	7.3 Unsafe Operating Conditions	34
3.3.2 Unpacking procedure	17		
3.3.3 Packing List	17	8. Specifications	35
		8.1 General Specifications	35
4. Installation	18	8.2 User Interface	35
4.1 Installing the Cabinet	18	8.3 Communication	35
4.2 Electrical Wiring	21	8.4 Environmental	35
4.2.1 Connecting the PE Wire	21	8.5 Mechanical	36
4.2.2 Connecting the Enclosure to Earth	21	8.6 Certification	36
4.2.3 Connecting the AC Input Wire	21		
4.2.4 Connecting the Ethernet Wire	21	Appendix A: Sticker instructions	37
4.2.5 Installing SIM Card	21		
4.3 External AC Input Protections	22	Appendix B: Simplified EU Declaration of Conformity (DoC)	38
4.3.1 Overcurrent protection	22		

1. General

1.1 Introduction

This manual describes the installation and operation of the RAEDIAN Galaxy V Series. Some illustrations may include modules or optional equipment not part of the standard configuration. For information on the availability of additional modules, optional tools, or accessories, contact your sales representative. This manual is intended for owners and installation engineers.

1.2 Intended Use

RAEDIAN Galaxy V Series is a mid-power DC charging platform for the European market, covering 50 kW / 60 kW / 80 kW with dual-outlet CCS2 DC interfaces. It is designed for urban public and semi-public scenarios: commercial centres, parking lots, service stations, and fleet charging.

DANGER

RAEDIAN is not liable for any risk and damage related to any use other than the use described in this manual. The equipment shall only be used in accordance with the intended use set out in this manual.

NOTE

The equipment can only be connected to the electricity grid in countries for which it has been certified. Only use accessories provided by RAEDIAN that comply with local laws and regulations.

1.3 Overview

1.3.1 Outside View

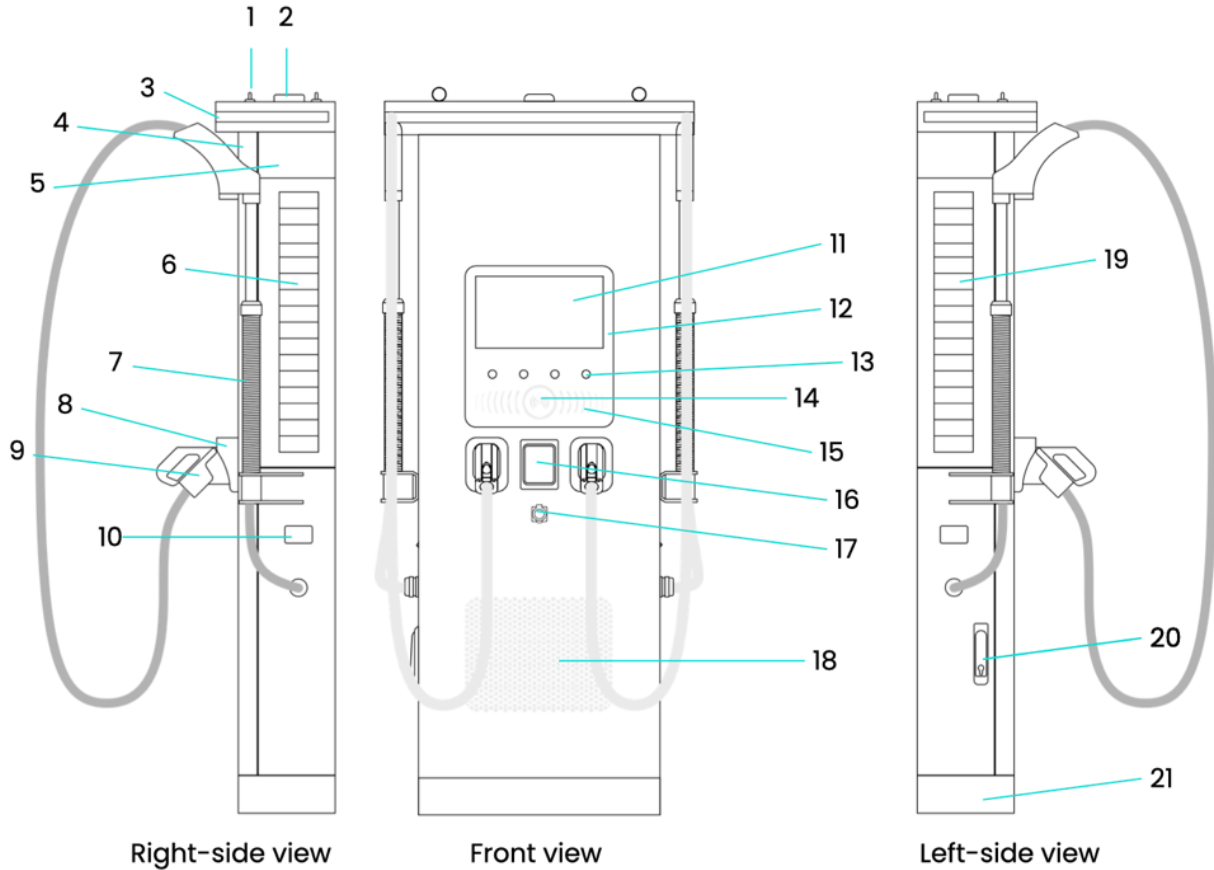

- | | |
|--|---|
| <ul style="list-style-type: none"> 1. Eye bolt 2. Antenna 3. HALO rooftop lighting 4. Front cabinet door 5. Main cabinet 6. Right-side air inlet 7. Spring CMS 8. Holster 9. CCS2 connector 10. Meter transparency window 11. 15.6-inch HD displays | <ul style="list-style-type: none"> 12. Tampered glass 13. Buttons 14. RFID card reader 15. Charging wave LED indicator 16. Payment terminal (optional) 17. TE Socket (optional) 18. Front air inlet 19. Left air outlet 20. Handle lock 21. Front/Rear Base Cover |
|--|---|

1.3.2 Inside View

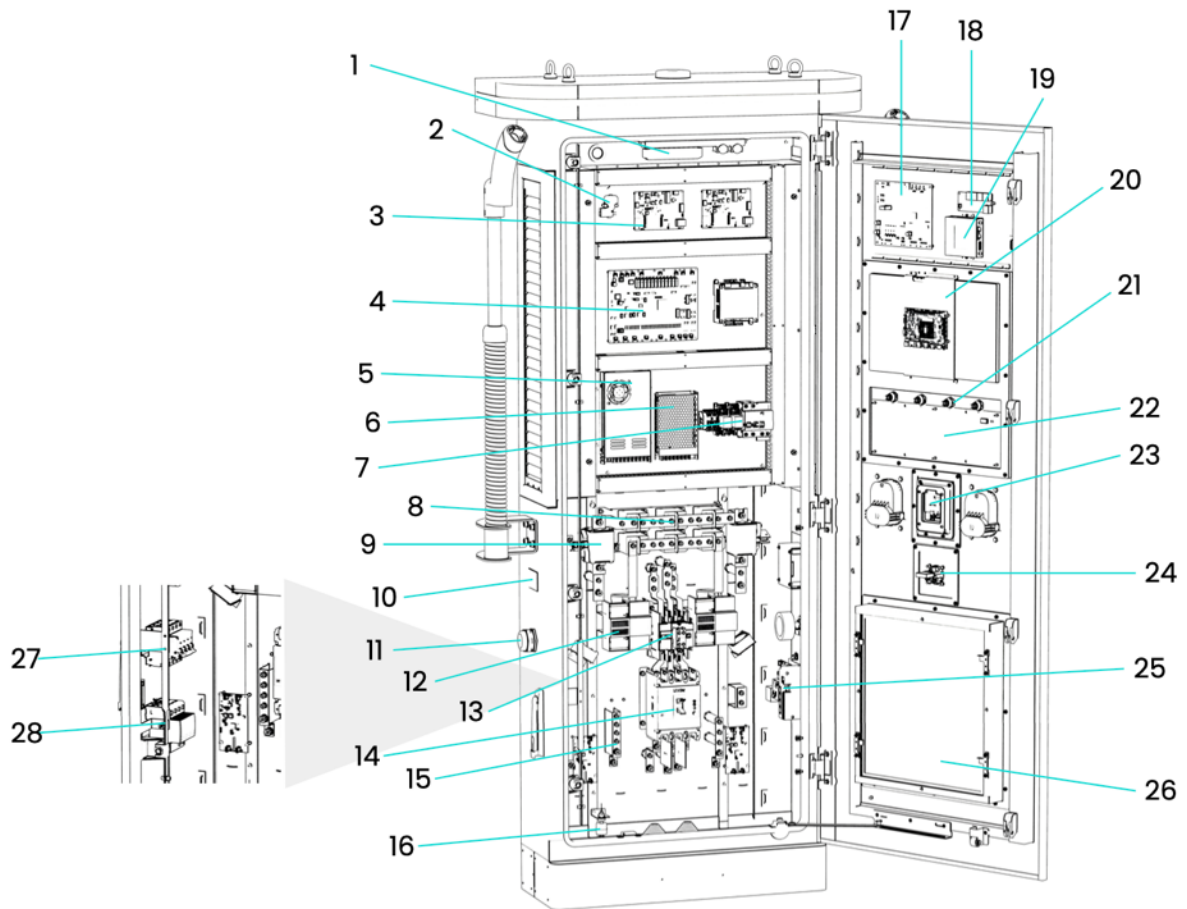

- 1. Door contact & lighting
- 2. Tilt sensor
- 3. SECC
- 4. CCU
- 5. 24V DC PSU
- 6. 12V DC PSU
- 7. AUX protections
- 8. DC switch matrix
- 9. DC fuse
- 10. Meter display unit
- 11. Charging cable gland
- 12. Meter
- 13. AC contractor
- 14. MCCB

- 15. Isolation monitor
- 16. Water sensor
- 17. Gateway
- 18. ETH switch
- 19. LTE router
- 20. HD display
- 21. Buttons
- 22. HMI board
- 23. Payment terminal
- 24. TE socket
- 25. TE block
- 26. Air inlet filter
- 27. MCB
- 28. SPD

1.3.3 Cable Management System

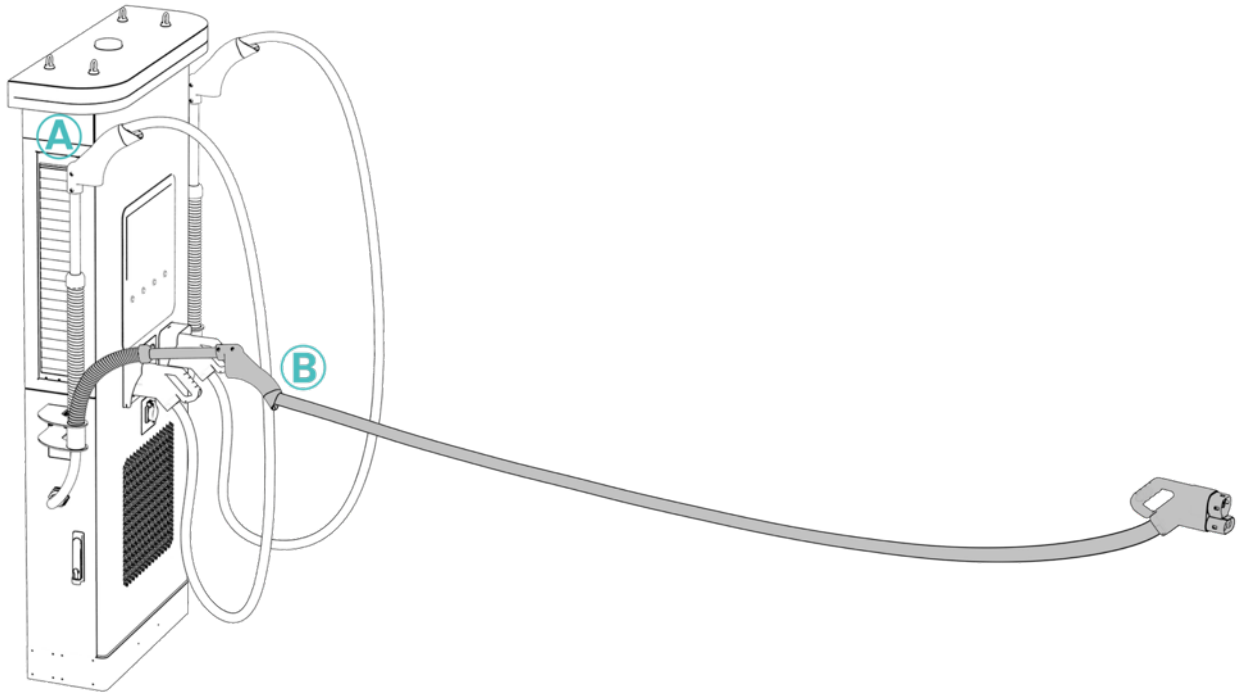

The spring cable management system enables smooth 360° rotation and up to 90° vertical articulation while maintaining a minimum 8× cable diameter bending radius for safe and durable cable movement.





Ref.	Part
A	CMS rest position
B	CMS extended position

NOTE

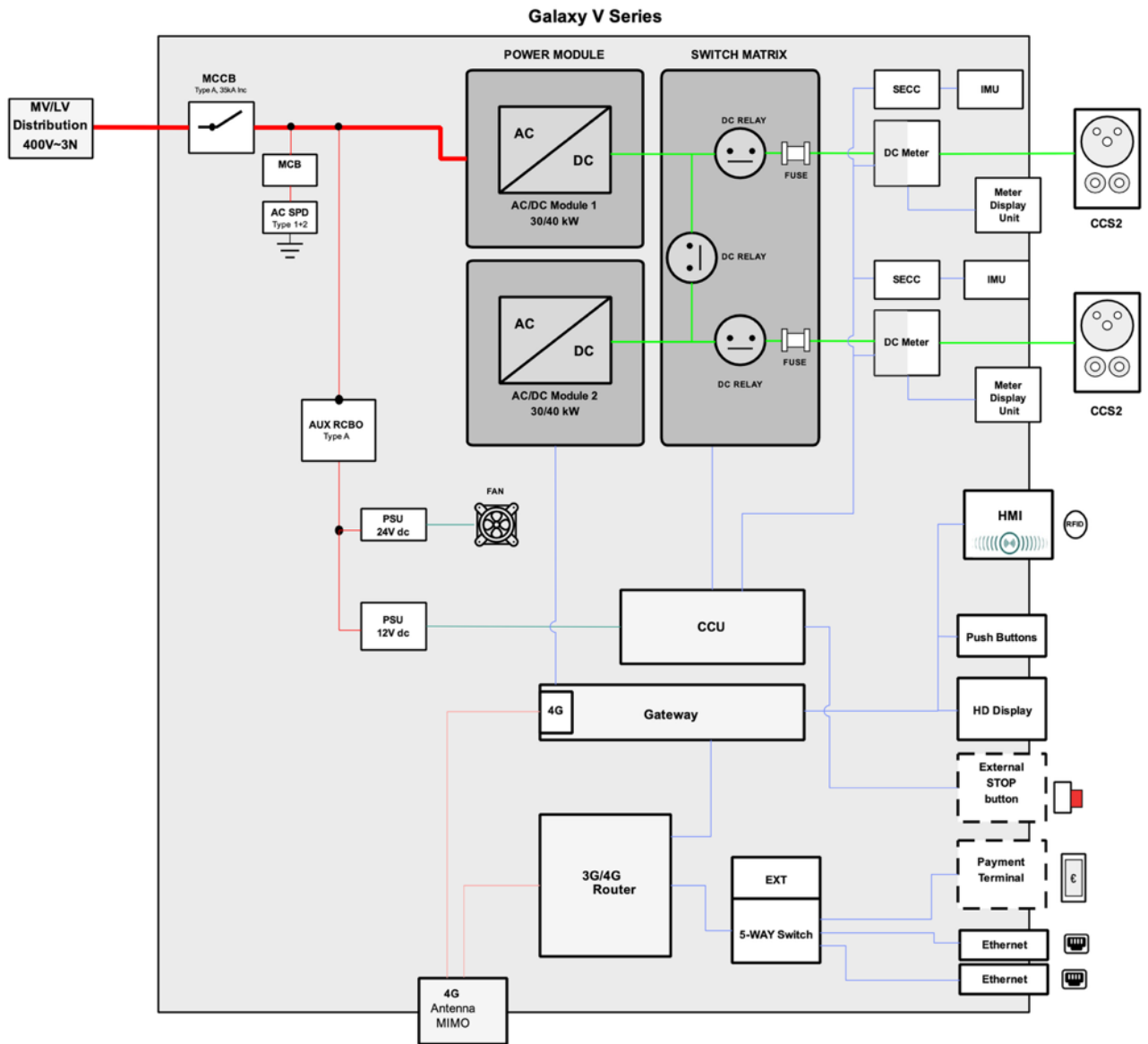



The illustration shows how the CMS of output 1 works. The same applies to the CMS of output 2.

1.3.4 Working Principal Diagram



Colours	Description
	AC power line
	DC power line
	Control signal communication
	Antenna

1.4 Symbols

Symbol	Description
	General risk
	Hazardous voltage, risk of electrocution
	WEEE – waste from electrical and electronic equipment
	Hot surface, risk of burn injuries

1.5 Terminology

Term	Description
AC	Alternating Current
CCS	Combined Charging System: An international standard for DC fast charging connectors and communication protocols.
CCU	Charging Control Unit: The main controller responsible for managing communication with the vehicle's Battery Management System (BMS) and regulating power output during charging.
DC	Direct Current
EV	Electric Vehicle
IMD	Insulation Monitoring Device: A safety device in DC charging systems that continuously monitors insulation resistance between live conductors and protective earth to detect leakage faults at an early stage.
MCB	Miniature Circuit Breaker: A protective device designed to automatically disconnect a circuit in the event of overload or short circuit.
MCCB	Molded Case Circuit Breaker: A high-capacity circuit protection device with adjustable trip settings, used for main power distribution circuits.
OCPP	Open Charge Point Protocol: An open communication standard between charging stations and central management systems (CMS).
PE	Protective Earth: A grounding conductor used for electrical safety protection against electric shock.
RCBO	Residual Current Breaker with Overcurrent Protection: A device combining residual current protection and overload/short-circuit protection.
RCD	Residual Current Device: A safety device that automatically disconnects a circuit when leakage current to earth is detected.
RFID	Radio Frequency Identification: A contactless technology used for user authentication at the charging station.
SECC	Supply Equipment Communication Controller: The communication controller within the charging station that manages communication with the electric vehicle.
SOC	State of Charge: The remaining battery capacity of an electric vehicle, expressed as a percentage of its total capacity.
SPD	Surge Protection Device: A device designed to protect electrical systems from voltage spikes and transient surges on AC power lines.

2. Safety Information

2.1 Liability

The manufacturer declares compliance with applicable regulations. The manufacturer is not liable for damage resulting from: unprofessional handling, non-compliance with manual, power outages, dirt/foreign substances, corrosion, cyber security breaches, vermin, external faults, natural hazards, improper installation, operation outside design conditions, incorrect maintenance, or improper storage.

2.1.1 Installation Engineer Qualifications

Engineers must be qualified per local regulations, familiar with the Galaxy V Series and its safe installation and comply with all local regulations and this manual.

2.1.2 Responsibilities and Qualifications for Users

Operators must comply with laws, identify hazards, operate with protective devices, prepare emergency plans, and ensure sufficient workspace.

2.2 Precautions for Use

2.2.1 Transportation

Wear PPE. Use approved hoisting/forklift equipment. Follow equipment safety instructions.

2.2.2 Installation

Ensure no voltage on input cables before work. Use the correct wire gauges. Do not modify the internal electrical configuration. Protect cables from damage. Do not open covers in adverse weather. Connect to Protective Earth (PE). Comply with local rules.

2.2.3 Operation

Do not use if damaged, after a lightning strike, fire risk, water ingress, or impact.

2.2.4 Maintenance

Wear PPE. Ensure no voltage during cleaning/maintenance. Reinstall safety devices after work.

2.2.5 Disposal

Dispose of according to local laws and the WEEE directive. Do not mix with household waste.

2.3 Personal Protective Equipment

Wear protective clothing, safety gloves, shoes, and glasses as necessary.

2.4 Cyber Security

The owner is responsible for establishing and maintaining appropriate measures (firewalls, authentication, encryption, antivirus) to protect against security breaches. RAEDIAN is not liable for damages related to data breaches or unauthorized access.

3. Preparation

3.1 Before Installation

Ensure: site prepared, all parts/tools available, correct wiring and circuit protection, proper grounding, cellular signal > -90 dBm (or install repeater), sufficient space for forklift and personnel.

CAUTION

In thunderstorm-prone regions, install an additional surge protection device at the main service panel. Always check local codes.

NOTE

For Ethernet, ensure internet connection is available. Consider cable inlet diameter.

3.2 Location Requirements

An installation site design is a prerequisite for determining conduit and wiring requirements from the panel to proposed parking spaces, as well as for measuring cellular signal strength and identifying suitable locations for any necessary cellular signal booster equipment.

Find a suitable location to ensure normal operation and proper airflow around the unit. The space is calculated as follows:

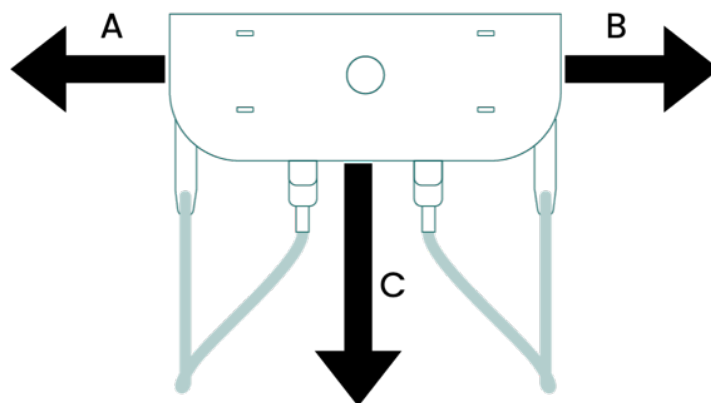

Parameter	Description	Specifications
A	Space to the left side	>500 mm
B	Space to the right side	>500 mm
C	Space to open the front door	>800 mm

1. Dig a hole according to the specified foundation dimensions.

CAUTION

The minimum foundation size for Galaxy V Series is 850×900×600 mm
 In thunderstorm-prone regions, install an additional surge protection device at the main service panel. Always comply with local electrical regulations.

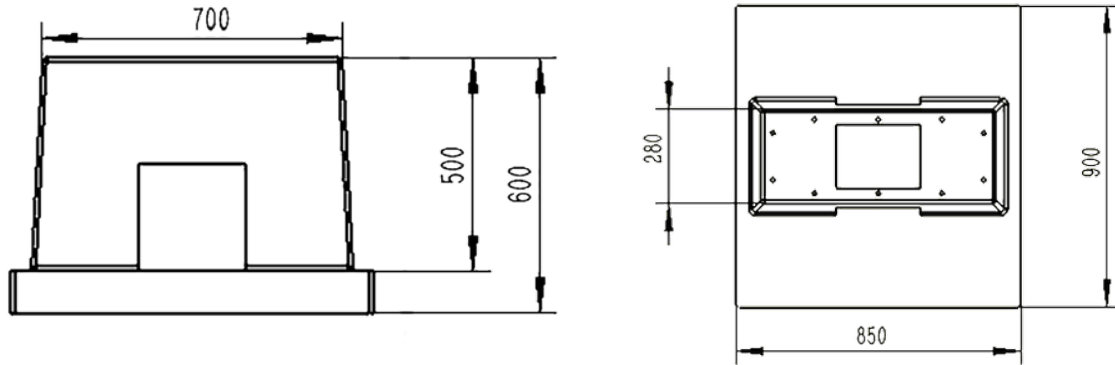

2. Position the cable duct/conduit according to the foundation layout drawing. Ensure the conduit exits within the designated cable entry area.

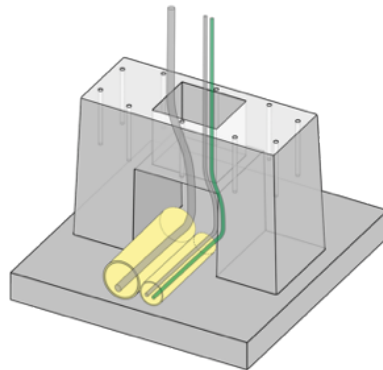

3. Install and secure the anchor bolts according to the charger base mounting-hole drawing. Verify the bolt spacing, orientation, and vertical alignment before pouring concrete.

NOTE

Refer to the charger base mounting-hole drawing provided in this manual for the exact anchor bolt locations and dimensions.

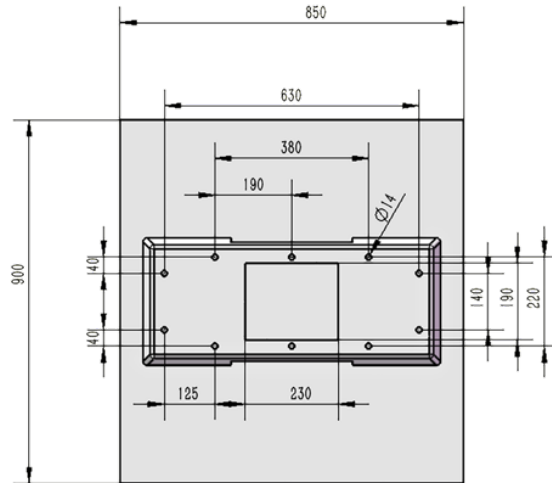

4. Pour concrete into the foundation hole, ensuring that the conduit and anchor bolts remain correctly positioned during pouring.
5. Allow the concrete foundation to fully cure before proceeding with installation.
6. Pull the power cables through the conduit. Leave sufficient cable length according to the following specifications.

Parameter	Specifications
Required Cable Slack for the Ethernet Cable (Measured from the Top of the Foundation)	>360 mm
Required Cable Slack for the AC input Cable (Measured from the Top of the Foundation)	>550 mm

3.3 Unpacking

3.3.1 Forklift truck / Wheel loader pallet fork

Read and follow the operating and safety instructions labelled on the package. Use a forklift. Do not drop or tilt more than 30°. Avoid excessive force on hoisting points. Wear PPE.

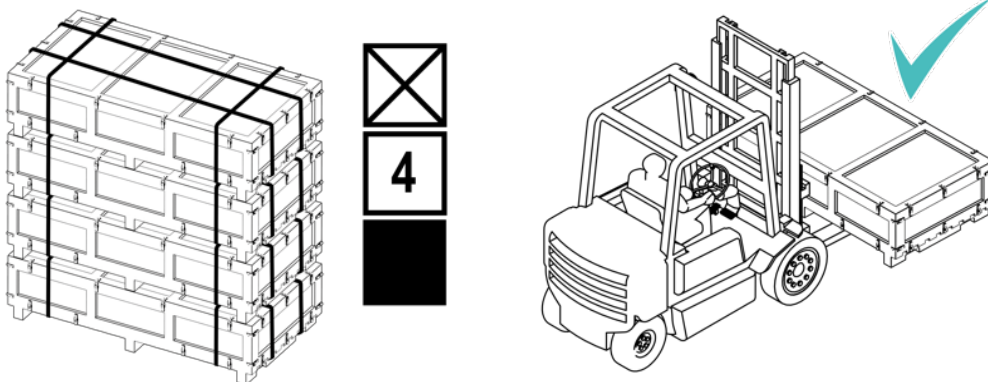

3.3.2 Unpacking procedure

1. Cut and remove the plastic straps.

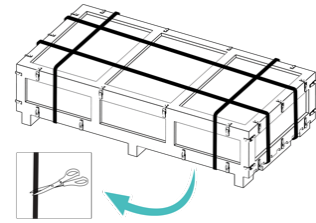

2. Remove the top cover and four cardboard walls

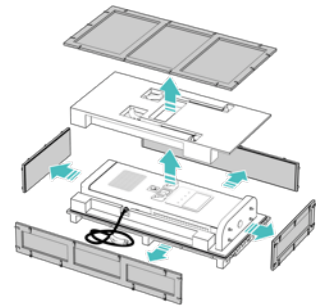



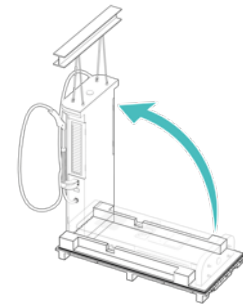





3. Use a crane or lifting equipment to hoist the charger and place it on a flat, stable surface near the installation site.



3.3.3 Packing List

When the Galaxy V Series is unpacked, make sure all components supplied are present:

<p>Galaxy V Series × 1</p> 	<p>Expansion bolt (M12×200) × 10</p> 
<p>Cabinet door key × 2</p> 	<p>Eye bolt (M12×20) × 4</p> 
<p>Bolt (M12×20) × 4</p> 	<p>Admin badge × 2</p> 
<p>Installation & operation manual × 1</p> 	<p>Packing list × 1</p> 

4. Installation

CAUTION

Installation must be performed by an installation engineer. Obtain required permits. Ensure the AC input cable is available. Check voltages before powering-on. Ensure no voltage during installation.

4.1 Installing the Cabinet

1. Open the front door

Remove the CCS2 connectors from the holsters and place them carefully on the ground, avoiding any damage. Use the door key to unlock the swing handle and quarter-turn locks, then open the front door.

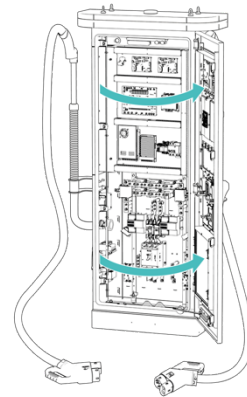

2. Remove the bottom cable entry cover plate

Remove the cover plate located at the bottom cable entry area of the charger.

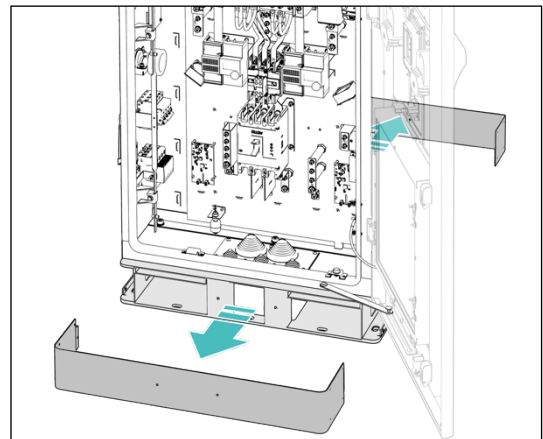

3. Remove the Cable Entry Plate

Unscrew and remove the cable entry plate from the bottom of the charger.

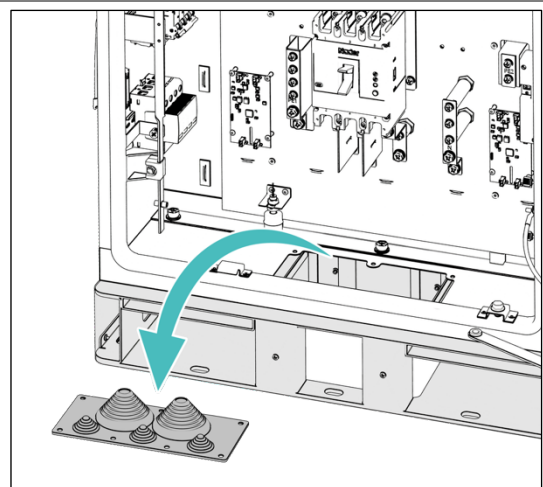

4. Mount the charger to the foundation

Align the charger with the installation position and secure the bottom mounting holes to the concrete foundation using anchor bolts (M12×200).

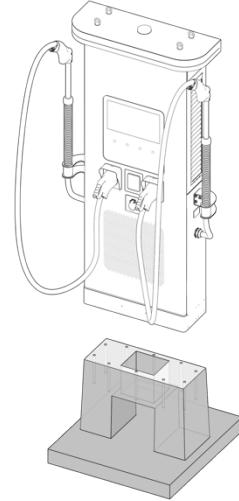

5. Route the cables

Cut the stepped rubber grommets to match the cable diameters. Route the power cables and communication cables through the cable entry plate.

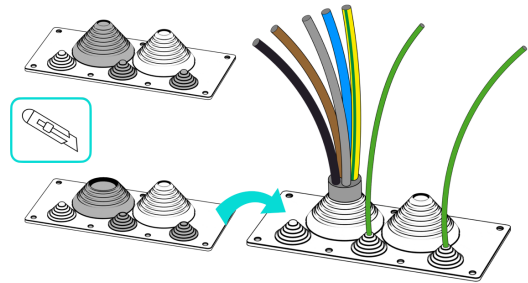

6. Reinstall the cable entry plate and complete the wiring

Complete all electrical and communication cables.

- AC multicore cable (L1, L2, L3, N, and PE) (A)
- Ethernet upstream (B)
- Ethernet downstream (C)

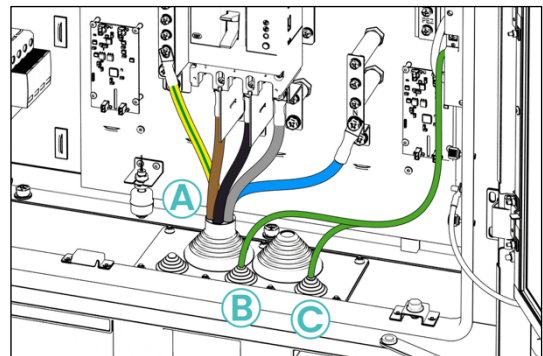

7. Reinstall the Bottom Cable Entry Cover Plate

Reinstall and secure the bottom cable entry cover plate after cable routing is completed.

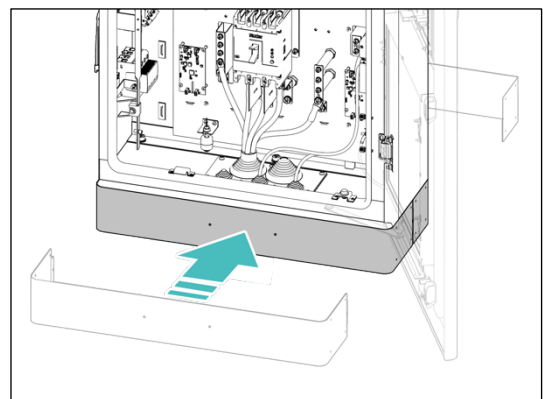

8. Close the front door

Close and secure the front door, then return the CCS2 connector to its holster.

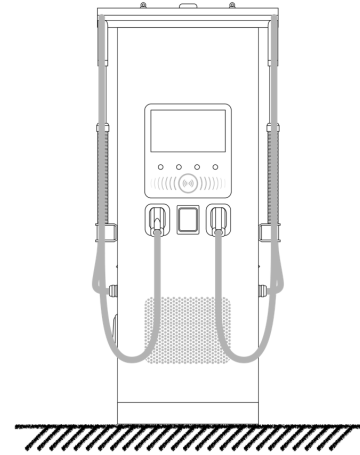
**9. Remove the eyebolts on the roof**

Remove all eyebolts from the roof of the charger and install the bolts (M12×20) into the mounting holes.

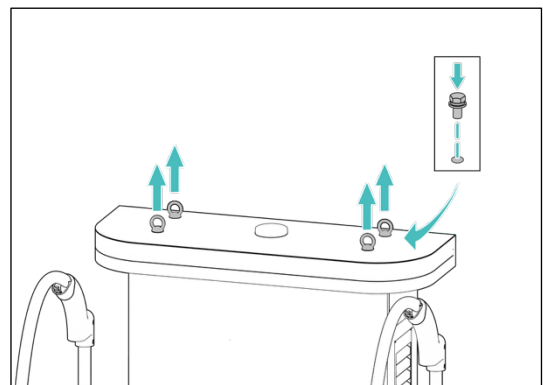

4.2 Electrical Wiring

Protective Earth Connection

A protective earth (PE) connection is mandatory.

Before performing any operation, ensure that all external power supply switches are in the OFF position and verify the absence of voltage on the AC conductors.

The RAEDIAN Galaxy V Series must be properly earthed through the connection points marked with the protective earth symbol. Use a protective earth conductor with an appropriate cross-sectional area suitable for the maximum prospective ground fault current of the system.

The protective earth connection shall be made via the internal PE busbar provided inside the equipment.

CAUTION

In accordance with applicable laws, regulations, and standards, the protective earth conductor shall have a minimum cross-sectional area equal to at least half that of the phase conductor. This requirement is valid only when the protective earth conductor is made of the same material as the phase conductors. If different conductor materials are used, the cross-sectional area of the protective earth conductor shall be selected to provide equivalent electrical conductivity.

4.2.1 Connecting the PE Wire

Cut PE wire to reach PE busbar, strip 20 mm, crimp cable lug, attach with fastener, tighten to 20.5 ± 2.5 Nm.

4.2.2 Connecting the Enclosure to Earth

Connect the earthing conductor from the enclosure pin to the earthing electrode.

4.2.3 Connecting the AC Input Wire

Cut N, L1, L2, L3 to length, strip, crimp lugs, attach to AC fuse copper busbar (L1→A, L2→B, L3→C, N→D). Tighten to 20.5 ± 2.5 Nm. Use cable ties. Seal conduit opening.

4.2.4 Connecting the Ethernet Wire

Plug the Ethernet cable into the RJ45 port.

4.2.5 Installing SIM Card

Press the button to eject the tray and insert the SIM card correctly.

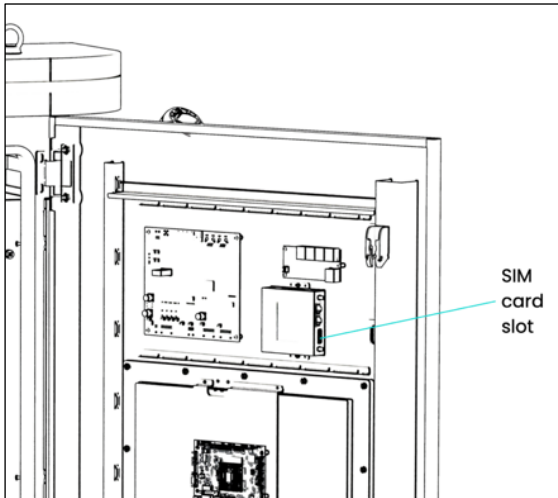

4.3 External AC Input Protections

The following schematic illustrates the typical position of external AC protection devices used in the installation.

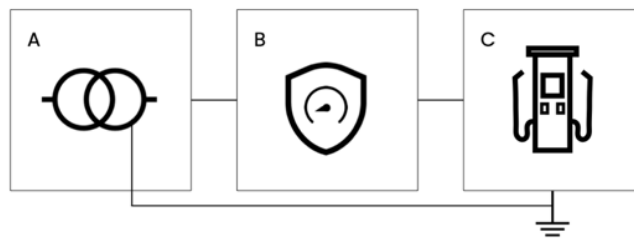

Parameter	Description
A	Medium voltage / Low voltage transformer
B	Low-voltage protection devices: <ul style="list-style-type: none"> • Overcurrent protection • Residual Current Device (RCD) • Type I Surge Protection Device (SPD)
<p>CAUTION This information does not supersede any legal regulations. The installer should be aware that local regulations may impose requirements not reflected in this document. The most stringent requirements shall be applied.</p>	
C	EVSE

4.3.1 Overcurrent protection

An external overcurrent protection device shall be installed on the AC supply line between the transformer and the EVSE.

The protection system may be implemented using one of the following configurations:

1. Main switch + 3 × 160 A fuses (gG or aG)
2. 3 × 160 A fuses (gG or aG)
3. 3-pole 160 A circuit breaker (thermal protection optional)

NOTE

In weak or unstable grid conditions, the AC input voltage may drop below the nominal value. Under these conditions, the EVSE may draw higher input current to maintain output power. This behaviour shall be considered when selecting and sizing the external overcurrent protection device.

The table below provides reference values for protection sizing

Parameter	Galaxy V Series
Rated AC input current	120 A @ 400 VAC
Maximum AC input current	85 A @ 360 VAC (-10%)
Maximum energy withstands short-circuit capability	0.9 MA ² s

4.3.2 Residual Current Device (RCD) Protection

DANGER – HAZARDOUS VOLTAGE

Where required by local electrical installation regulations, an external RCD shall be installed.

The RCD shall be Type B/B+, with adjustable residual operating current ($I_{\Delta n}$).

In thunderstorm-prone regions, install an additional surge protection device at the main service panel. Always check local codes.

NOTE 1

Using an RCD with excessively low residual operating current may increase the risk of nuisance tripping, depending on the installation design and system configuration.

NOTE 2

In installations where multiple EVSE units are protected by a single RCD, adjustment of tripping current and tripping delay settings may be required to ensure selective coordination.

To reduce the risk of nuisance tripping, the RCD should meet the following recommendations:

RCD Specification	Galaxy V Series
Type	B / B+
Recommended sensitivity ($I_{\Delta n}$)	100 mA

4.4 Preparing for Commissioning

CAUTION

Only a manufacturer-certified service engineer can commission the RAEDIAN's Galaxy V Series.

4.4.1 Site readiness requirements

Before commissioning, ensure the following conditions are met:

- The RAEDIAN Galaxy V Series has been installed in accordance with this manual.
- AC input power is available at the installation site.
- Internet connectivity is available via one of the following methods:
 - Wi-Fi
 - Wired Ethernet connection
- At least one compatible EV is available for each connector type for functional testing.
- The site operator or owner is present to receive instructions from the manufacturer-certified service engineer during commissioning.

4.4.2 Required information

Ensure the following information is collected before commissioning:

- Site name and address
- Contact details of the on-site responsible person
- Specification of external protection devices (fuses or circuit breakers) in the distribution panel
- Installation completion date
- Photos of the charger and the surrounding installation environment
- Any special remarks or site-specific considerations

4.4.3 Power energization support

A responsible person must be present on site to assist in energizing the RAEDIAN Galaxy V Series from the distribution panel when required.

4.4.4 Accessing the web configuration interface

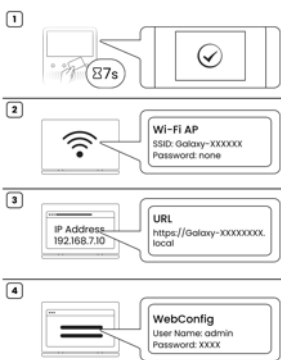
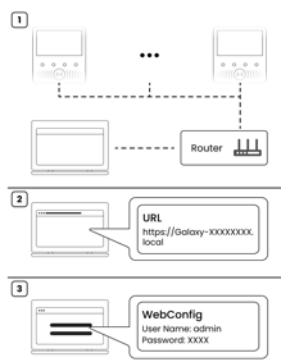
Via Wi-Fi	<ol style="list-style-type: none"> 1. Tap the service RFID card on the card reader for 7 seconds to activate the charger's built-in Wi-Fi hotspot. 2. Connect the commissioning laptop to the charger's Wi-Fi network. The Wi-Fi SSID is provided on the product label. 3. Enter the specified IP address in a web browser. 4. Log in to the Web Configuration interface. 	
Via Ethernet	<ol style="list-style-type: none"> 1. Connect the commissioning laptop directly to the charger using an Ethernet cable. 2. Enter the specified IP address in a web browser. 3. Log in to the Web Configuration interface. 	

5. Operation

5.1 Before Use

Before operating the charger, ensure that the following conditions are met:

1. Verify that the charger is securely installed and fixed according to the installation requirements.
2. Ensure that the incoming power supply is connected correctly and that the rated input voltage is available.
3. Confirm that all protective devices, including MCCB, MCB, RCBO, SPD, and fuses, are in normal operating condition.
4. Check that the emergency stop button is released and not activated.
5. Verify that the display, communication modules, RFID reader, and payment terminal (if equipped) are functioning properly.
6. Ensure that the charging connector, cable assembly, and connector contacts are free from visible damage, deformation, or contamination.
7. Confirm that the ventilation openings are unobstructed and that adequate clearance is maintained around the charger.
8. Ensure that no alarm, fault, or warning message is displayed on the HMI before starting a charging session.
9. Verify that network communication is available when remote operation, payment services, or OCPP connectivity is required.
10. Make sure the charging area is dry, clean, and free from flammable, explosive, or corrosive materials.

5.2 Charging Procedure

5.2.1 Screen Layout



Parameter	Function	Description
1	Screen saver	Display promotional content on the home screen.
2	Help	View charger information and customer support details.
3	Language Selection	Switch the user interface language.
4	Tariff Information	View charging rates and pricing details.
5	Start Charging	Select the corresponding connector to begin charging.
6	4G Connection Status	Indicates the current 4G network connection status.
7	LAN Connection Status	Indicates the current LAN connection status.

When a connector is successfully plugged into your EV, the RAEDIAN Galaxy V Series automatically detects the connection and displays the corresponding authorization screen. If no action is taken for a certain period, the interface will automatically return to the home screen. Tap the corresponding button to enter the connector selection page, then select the connected connector to start charging.

5.2.2 Authorization

NOTE

Observe the screen for any abnormalities, such as an error message, before starting a charge session. Check the surroundings and the RAEDIAN's Galaxy V Series for any abnormalities or damage. If the screen displays an error message, DO NOT use the RAEDIAN's Galaxy V Series. Contact RAEDIAN Technical Support.

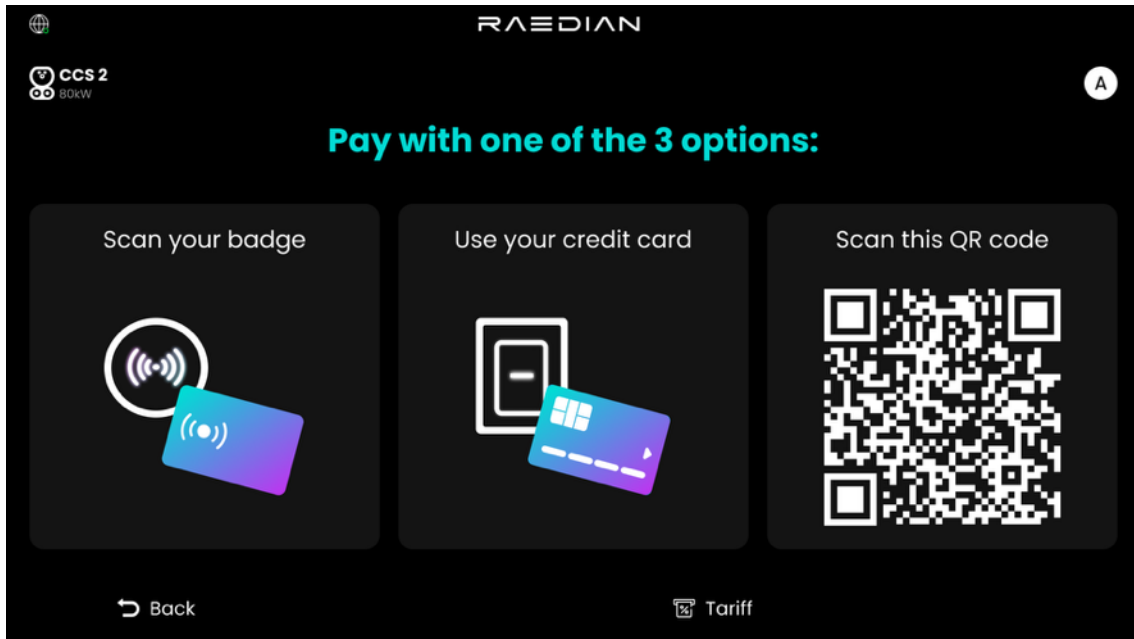

When the Authorization Screen appears, you can start charging using an RFID card, contactless payment card, or by scanning the QR code.

5.2.3 Start Charging

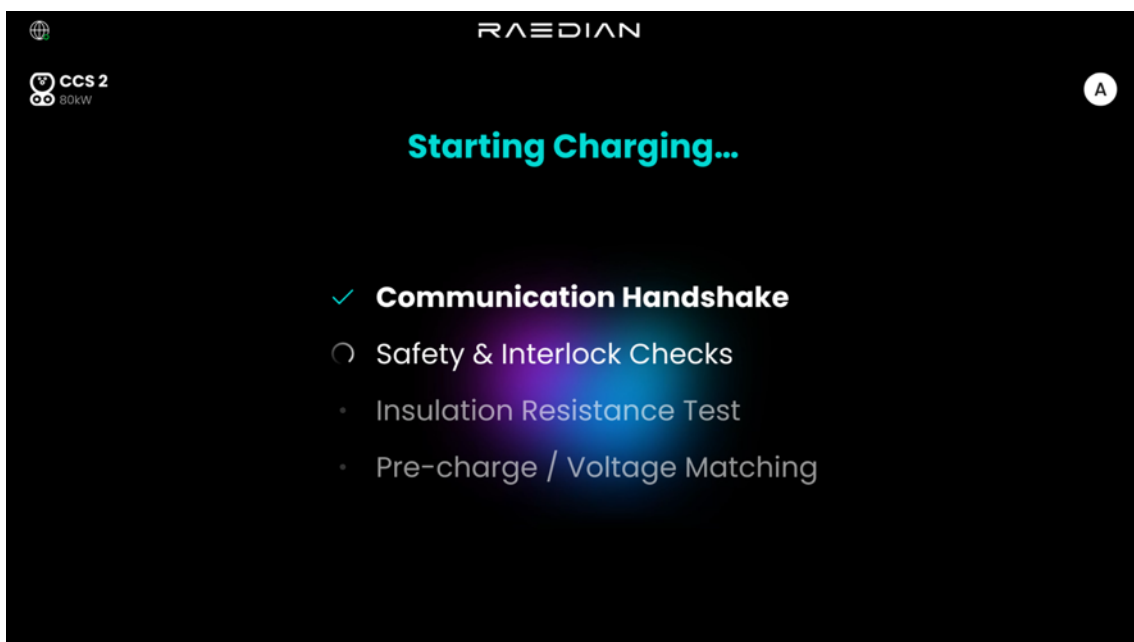

After authorization, communication and safety tests run automatically, then charging starts.

5.2.4 Charging

NOTE

The charging time to 80% is for reference only; the actual charging time depends on EV.

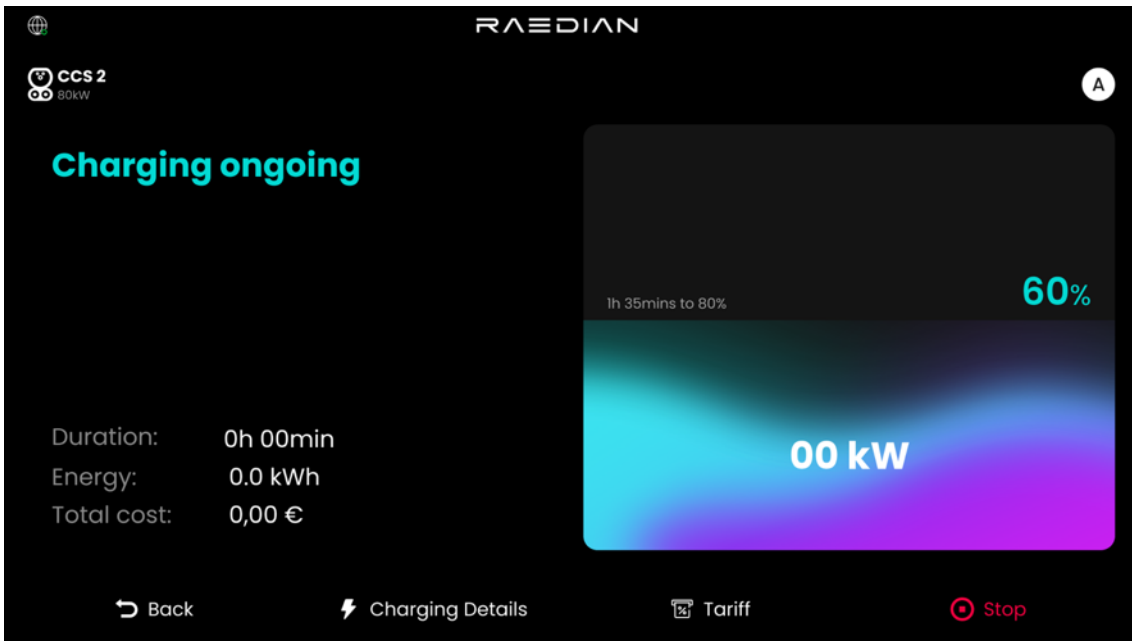

The screen shows duration, volume, cost, and power. Tap Stop to end the session.

5.2.5 Stop Charging

NOTE

Charging will stop automatically once the target state of charge (SOC) set by user is reached.

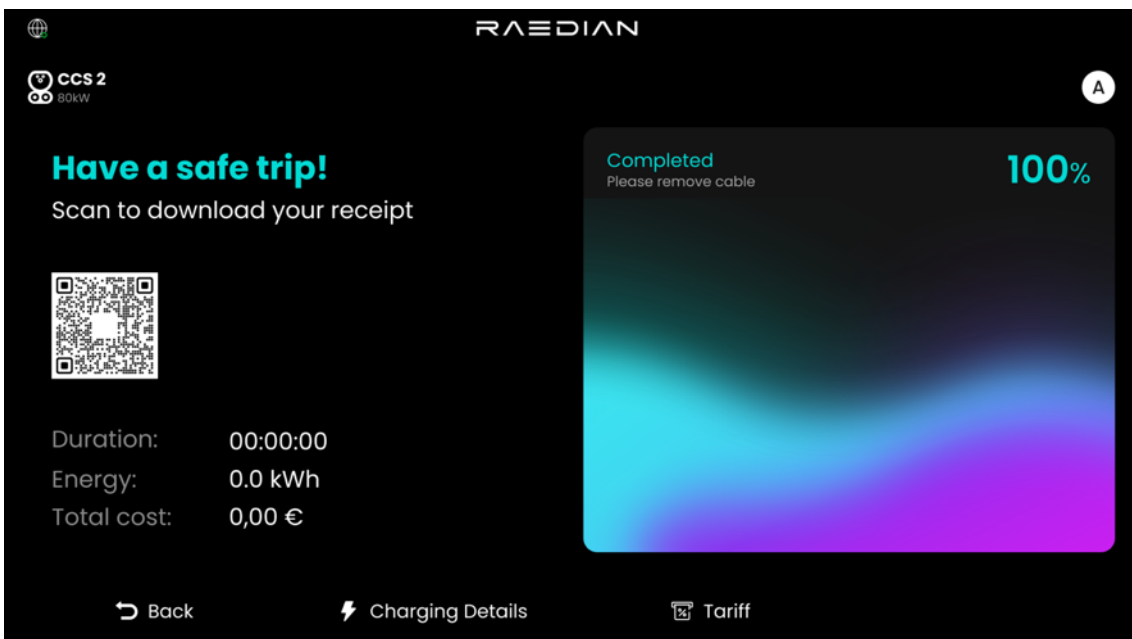

Tap Stop, then present RFID card again (if required). Disconnect cable and return to holster.

5.2.6 Finish Charging

Return the connector to holster.

5.3 Charging Errors

Connector connection error, authorization failed, start failure, charging failure – follow on-screen instructions. If persistent, contact support.

5.4 Energizing the Galaxy V Series

Close the front door, set the upstream breaker to ON.

5.5 De-energizing the Galaxy V Series

Set upstream breaker OFF and lock. Open door. Measure AC and DC voltage – ensure 0 V. Close door.

5.5.1 Measuring AC Voltage

Measure between L1-L2, L1-L3, L2-L3, and N to each line on the SPD switch.

5.5.2 Measuring DC Voltage

Remove insulating barrier, measure between power module outputs and EV cable outputs – must be 0 V.

6. Maintenance

6.1 Maintenance Schedule

To ensure safe and reliable operation, periodic maintenance shall be performed by qualified personnel.

Item	Inspection	Interval
Enclosure	Damage, corrosion, sealing condition	Monthly
Display & HMI	Functionality and readability	Monthly
CCS2 connectors	Wear, overheating, contamination	Monthly
Charging cables	Cracks, deformation, abrasion	Monthly
Cooling fans	Airflow and noise level	Quarterly
Internal electrical connections	Tightness and overheating signs	6 Months
DC fuses	Visual inspection	6 Months
SPD devices	Status indication	6 Months
MCCB / RCBO	Functional inspection	6 Months
Energy meters	Verification	Annually

6.2 Cleaning

Before cleaning:

1. Stop all charging sessions.
2. Disconnect the charger from the power supply.
3. Wait for internal capacitors to discharge.

Cleaning instructions:

- Use a soft dry cloth.
- Use a damp cloth for stubborn dirt.
- Do not use solvents or abrasive cleaners.
- Do not use pressure washers.
- Do not allow liquids to enter the enclosure.

6.3 Preventive Maintenance

Qualified service personnel should periodically:

- Check the insulation condition of power circuits.
- Verify the correct operation of DC contactors and relays.

- Inspect fuse condition.
- Verify cooling fan operation.
- Confirm proper operation of SECC communication with electric vehicles.
- Update firmware and software when approved by the manufacturer.

7. Troubleshooting

7.1 General Troubleshooting

The following issues may be resolved by the user without opening the charger enclosure

Symptom	Possible Cause	Corrective Action
Charger does not start charging	Charging connector not fully inserted	Reinsert the charging connector and ensure it is securely connected.
	Authentication failed	Retry RFID card, mobile payment or other authorization method.
	Vehicle not ready for charging	Check vehicle charging settings and battery status.
Charging session stops unexpectedly	Vehicle terminates charging	Check vehicle status and charging settings.
	Temporary communication interruption	Reconnect the charging connector and restart the charging session.
Charging connector not recognized	Connector not properly inserted	Disconnect and reconnect the charging connector.
	Connector or cable damaged	Inspect the connector and cable for visible damage. Contact service personnel if necessary.
Vehicle handshake fails	Temporary communication issue between charger and vehicle	Reconnect the charging connector and retry charging.
	Vehicle compatibility issue	Verify that the vehicle supports the charging standard provided by the charger.
Output power appears lower than expected	Battery charging curve limitation	Charging power may decrease automatically at high battery State of Charge (SOC).
	High temperature derating	Charging power may be temporarily reduced to protect equipment.
Network connection unavailable	Ethernet or cellular network interruption	Verify network availability and retry later.
Payment terminal unavailable	Network interruption	Verify network connectivity and retry payment.
RFID card not accepted	Invalid or unauthorized card	Use an authorized RFID card and retry.
Charger displays an alarm message	Temporary operating condition detected	Follow the instructions displayed on the screen. If the alarm persists, contact service personnel.

7.2 Service Troubleshooting

The following procedures shall only be performed by qualified service personnel.

Symptom	Possible Cause	Corrective Action
Charger does not power on	No AC input power	Verify 400 VAC three-phase input voltage.
	MCCB open	Inspect and reset MCCB if appropriate.
	MCB or RCBO open	Inspect and reset the protective device after identifying the cause.
	Auxiliary power supply failure	Verify 12 VDC and 24 VDC PSU outputs.
HMI display remains blank after power-up	HMI power supply fault	Verify HMI supply voltage.
	Communication fault	Check communication connections between HMI and controller.
	HMI hardware failure	Replace HMI if necessary.
MCCB or MCB trips repeatedly	Input short circuit	Inspect input wiring and power circuits.
	Power module fault	Isolate and inspect power modules.
	Auxiliary circuit overload	Inspect connected loads and auxiliary circuits.
AC SPD alarm	SPD reached end of service life	Inspect SPD status indicator.
	Surge protection activated by lightning or transient event	Replace SPD with an equivalent type and rating.
Auxiliary power supply unavailable	PSU failure	Verify PSU input voltage and output status.
	Output short circuit	Disconnect loads and inspect output circuits.
Cooling fan not operating	Fan failure	Verify fan operation and replace if necessary.
	Power supply fault	Check fan supply voltage.
	Control signal fault	Verify controller output signals.
Frequent thermal derating	Air filter blocked	Clean or replace filters.
	Airflow restricted	Remove obstructions and verify ventilation paths.
	Ambient temperature too high	Verify installation environment complies with specifications.
Power module offline	Module power loss	Verify module AC input and protection status.
	Internal communication fault	Check communication wiring and module status.
	Configuration mismatch	Verify module configuration parameters.
Output power lower than rated	One or more power modules unavailable	Inspect module status and alarms.
	Thermal derating active	Verify cooling system operation.

	Power allocation abnormality	Verify system configuration and controller settings.
Charging connector not detected	CP signal abnormal	Verify CP circuit and wiring.
	PP signal abnormal	Verify PP circuit and wiring.
	Connector assembly fault	Inspect connector, cable and locking mechanism.
Vehicle handshake failure	SECC fault	Verify SECC operation and diagnostic logs.
	PLC communication failure	Inspect PLC communication status.
	Vehicle protocol incompatibility	Verify vehicle compatibility.
DC output unavailable	DC fuse open	Inspect and replace fuse if required.
	DC relay fault	Verify relay operation and control signals.
	Power module failure	Inspect module alarms and operating status.
Metering abnormality	Meter communication fault	Verify meter communication connections.
	Meter hardware failure	Replace the meter if necessary.
Ethernet communication unavailable	Network cable disconnected	Verify Ethernet connection.
	Gateway fault	Inspect gateway operating status.
Cellular communication unavailable	Antenna disconnected	Verify antenna installation.
	SIM card or network fault	Verify network registration status.
Payment terminal unavailable	Communication fault	Verify terminal communication.
	Payment terminal hardware failure	Replace terminal if necessary.

7.3 Unsafe Operating Conditions

CAUTION

Do not attempt to open the enclosure or repair internal components unless authorized and qualified to do so.

If any of the following conditions occur:

- Smoke, burning smell, or abnormal noise
- Electrical arcing
- Visible damage to the charger
- Water ingress into electrical compartments
- Repeated protection trips

Immediately:

1. Stop the charging session if it is still active.
2. Disconnect the charger from the upstream power supply.
3. Prevent further use of the charger.
4. Contact qualified service personnel for inspection and repair.

8. Specifications

8.1 General Specifications

Galaxy V Series	50kW	60kW	80kW
Input Rating	400VAC±10%, 50/60Hz, L1+L2+L3+N+PE		
Power Factor	≥0.99 @ full load		
Efficiency	≥96.8% @ full load (peak)	≥96.9% @ full load (peak)	≥97% @ full load (peak)
Grid Type	TN-S, TN-C, TN-C-S, TT		
Output Interface	2× CCS2, 1× Type E socket (optional)		
Output Power	CCS2: Up to 50kW Type E: 2.3kW	CCS2: Up to 60kW Type E: 2.3kW	CCS2: Up to 80kW Type E: 2.3kW
Output Voltage	CCS2: 200-1000VDC, AC: 230/400VAC ±10%		
DC Output Current	Up to 150A	Up to 150A	Up to 200A

8.2 User Interface

Display	15.6 inch
Support Language	EN/DE/FR/ES/IT/NL/PT (others on request)
HMI	270° RGB halo top lighting, RFID wave charging LED, 4×illuminated LED buttons
User Authentication	RFID badges (up to 500 local badges), dynamic QR code, App, contactless payment (optional)
RFID Reader	ISO/IEC 14443 A/B, ISO/IEC 18092, IEC/ISO 15693

8.3 Communication

Network Interface	Dual 4G LTE, Ethernet 10/100 Mbps
Protocol (EVSE & Backend)	OCPP 1.6J, OCPP 2.0.1/2.1 ready
Protocol (EVSE & EV)	DIN70121, ISO 15118-2/-20
Commissioning	WebConfig via LAN/WLAN
EMS Integration	Modbus TCP, RESTful API

8.4 Environmental

Operating Temperature	-30°C to +50°C (derating may apply)
Storage Temperature	-40°C to +70°C
Humidity	5% to 95% (non-condensing)
Altitude	≤2000m above sea level

8.5 Mechanical

IP Rating	IP55
IK Rating	IK10 (front housing), IK08 (tamper-resistant glass), IK07 (payment terminal)
Cooling	Forced-air cooling
Charging Cable Length	5m total cable length, 4.2m effective reach
Cable Management System	Spring
Installation	Ground-mounted

8.6 Certification

Standards & compliance	IEC 61851-1, IEC 61851-21-2, IEC 61851-23, LVD 2014/35/EU, RED 2014/53/EU, EN 18031
Certification	CE, Eichrecht (optional)

Appendix A: Sticker instructions

Log in to WebConfig and configure the charger

<p>1</p> <p>Diagram showing two chargers connected to a laptop and a router. Dashed lines indicate connections between the chargers, the laptop, and the router.</p>	<p>1</p> <p>Sticker with a checkmark and a 7s timer icon.</p>
<p>2</p> <p>Sticker with URL: <code>https://Gemini-EC0U0DLR.local</code></p>	<p>2</p> <p>Wi-Fi AP SSID: Gemini-0U0DLA Password: none</p>
<p>3</p> <p>WebConfig User Name: admin Password: ECU</p>	<p>3</p> <p>IP Address: 192.168.7.10 URL: <code>https://Gemini-EC0U0DLR.local</code></p>
	<p>4</p> <p>WebConfig User Name: admin Password: ECU</p>

Appendix B: Simplified EU Declaration of Conformity (DoC)

Manufacturer: Zhejiang RAEDIAN New Energy Technology Co., Ltd.

Address: No. 3 Shuangbai Road, Yuanhua Town, Haining, Zhejiang, China

Zhejiang RAEDIAN New Energy Technology Co., Ltd. hereby declares that the radio equipment:

Product: DC EV Charging Station

Model: Galaxy V Series

is in compliance with Directive 2014/53/EU (Radio Equipment Directive), Directive 2014/30/EU (Electromagnetic Compatibility Directive), Directive 2014/35/EU (Low Voltage Directive), Directive 2011/65/EU (RoHS Directive), and other applicable EU legislation.

The full text of the EU Declaration of Conformity is available at the following internet address:

<https://www.raedian.com/support/downloads>