

# Galaxy W Series

## Installation and Operation Manual

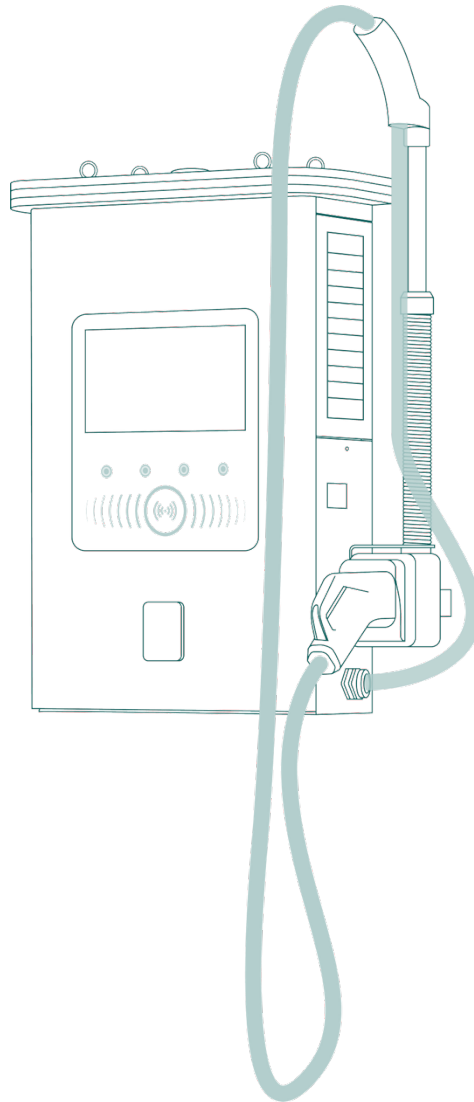

**30/40 kW**

**Public operation charging station**

### **Important Safety Information**

To ensure safe operation and full understanding of all product functions, read this manual carefully before using the product. Keep this manual in a readily accessible location near the equipment for future reference whenever operational guidance is required.

### **Disclaimer of Warranties and Limitation of Liabilities**

---

All information contained in this manual is based on the latest available data at the time of publication. RAEDIAN reserves the right to modify the contents of this manual without prior notice. Although every effort has been made to ensure accuracy, no guarantee is given regarding completeness or correctness, including but not limited to product specifications, functions, and illustrations. RAEDIAN shall not be held liable for any damage, loss, or cost arising from failure to comply with this manual or applicable standards and regulations. Failure to strictly follow the instructions will immediately void any applicable warranty. Any unauthorized modification, manipulation, or alteration — whether hardware or software — shall result in immediate termination of the warranty.

### **Copyright Notice**

---

Company names and model designations mentioned in this manual may be trademarks or registered trademarks of their respective owners. All content is the intellectual property of RAEDIAN New Energy Technology Corp., Ltd. ("RAEDIAN®") and is protected by copyright law. All rights reserved. No part of this manual may be reproduced, stored, or transmitted in any form or by any means without prior written permission from RAEDIAN.

### **Support**

---

Web: [www.raedian.com](http://www.raedian.com)

Email: [support@raedian.com](mailto:support@raedian.com)

For support in other markets, please get in touch with your local representative.

---

## Conventions Used in this Manual

---

### Dangers, Warnings, and Caution

---

Level	Description
<b>DANGER</b>	Indicates an imminently hazardous situation which, if not avoided, will result in death or serious injury.
<b>WARNING</b>	Indicates a potentially hazardous situation which, if not avoided, could result in death or serious injury.
<b>CAUTION</b>	Indicates a potentially hazardous situation which, if not avoided, may result in minor or moderate injury.
<b>NOTE</b>	Provides additional information such as explanations and tips.

---

**Bold Text** is used to highlight selectable items such as buttons and menu options.

## Content

<b>1. General</b> .....	<b>5</b>	4.3.1 Overcurrent protection.....	22
1.1 Introduction.....	5	4.3.2 Residual Current Device (RCD) Protection	23
1.2 Intended Use.....	5	.....	23
1.3 Overview.....	6	4.4 Preparing for Commissioning.....	23
1.3.1 Outside View.....	6	4.4.1 Site readiness requirements.....	23
1.3.2 Inside View.....	7	4.4.2 Required information.....	24
1.3.3 Cable Management System.....	8	4.4.3 Power energization support.....	24
1.3.4 Working Principal Diagram.....	9	<b>5. Operation</b> .....	<b>25</b>
1.4 Symbols.....	10	5.1 Before Use.....	25
1.5 Terminology.....	11	5.2 Charging Procedure.....	26
<b>2. Safety Information</b> .....	<b>12</b>	5.2.1 Screen Layout.....	26
2.1 Liability.....	12	5.2.2 Authorization.....	27
2.1.1 Installation Engineer Qualifications.....	12	5.2.3 Start Charging.....	27
2.1.2 Responsibilities and Qualifications for Users	12	5.2.4 Charging.....	28
.....	12	5.2.5 Stop Charging.....	28
2.2 Precautions for Use.....	12	5.2.6 Finish Charging.....	29
2.2.1 Transportation.....	12	5.3 Charging Errors.....	29
2.2.2 Installation.....	12	5.4 Energizing the Galaxy W Series.....	29
2.2.3 Operation.....	12	5.5 De-energizing the Galaxy W Series.....	29
2.2.4 Maintenance.....	12	5.5.1 Measuring AC Voltage.....	29
2.2.5 Disposal.....	12	5.5.2 Measuring DC Voltage.....	29
2.3 Personal Protective Equipment.....	13	<b>6. Maintenance</b> .....	<b>30</b>
2.4 Cyber Security.....	13	6.1 Maintenance Schedule.....	30
<b>3. Preparation</b> .....	<b>14</b>	6.2 Cleaning.....	30
3.1 Before Installation.....	14	6.3 Preventive Maintenance.....	31
3.2 Location Requirements.....	14	<b>7. Troubleshooting</b> .....	<b>32</b>
3.3.1 Forklift truck / Wheel loader pallet fork.....	16	7.1 Troubleshooting Guide.....	32
3.3.2 Unpacking procedure.....	16	7.3 Unsafe Operating Conditions.....	33
3.3.3 Packing List.....	17	<b>8. Specifications</b> .....	<b>34</b>
<b>4. Installation</b> .....	<b>18</b>	8.1 General Specifications.....	34
4.1 Installing the Cabinet.....	18	8.2 User Interface.....	34
4.2 Electrical Wiring.....	21	8.3 Communication.....	34
4.2.1 Connecting the PE Wire.....	21	8.4 Environmental.....	34
4.2.2 Connecting the Enclosure to Earth.....	21	8.5 Mechanical.....	35
4.2.3 Connecting the AC Input Wire.....	21	8.6 Certification.....	35
4.2.4 Connecting the Ethernet Wire.....	21	<b>Appendix A: Sticker instructions</b> .....	<b>36</b>
4.2.5 Installing SIM Card.....	21	<b>Appendix B: Simplified EU Declaration of</b>	
4.3 External AC Input Protections.....	22	<b>Conformity (DoC)</b> .....	<b>37</b>

# 1. General

## 1.1 Introduction

This manual describes the installation and operation of the RAEDIAN Galaxy W Series. Some illustrations may include modules or optional equipment not part of the standard configuration. For information on the availability of additional modules, optional tools, or accessories, contact your sales representative. This manual is intended for owners and installation engineers.

## 1.2 Intended Use

RAEDIAN Galaxy W Series is a mid-power DC charging platform for the European market, available in 30 kW / 40 kW power ratings. It is specifically designed for power-limited areas where grid capacity is constrained. The series features a CCS2 DC outlet as standard, with optional AC charging interfaces including a Type 2 socket and a Type E socket (TE). It is suitable for installation in urban and semi-public environments with limited grid capacity.

### **DANGER**

RAEDIAN is not liable for any risk and damage related to any use other than the use described in this manual. The equipment shall only be used in accordance with the intended use set out in this manual.

### **NOTE**

The equipment can only be connected to the electricity grid in countries for which it has been certified. Only use accessories provided by RAEDIAN that comply with local laws and regulations.

### 1.3 Overview

#### 1.3.1 Outside View

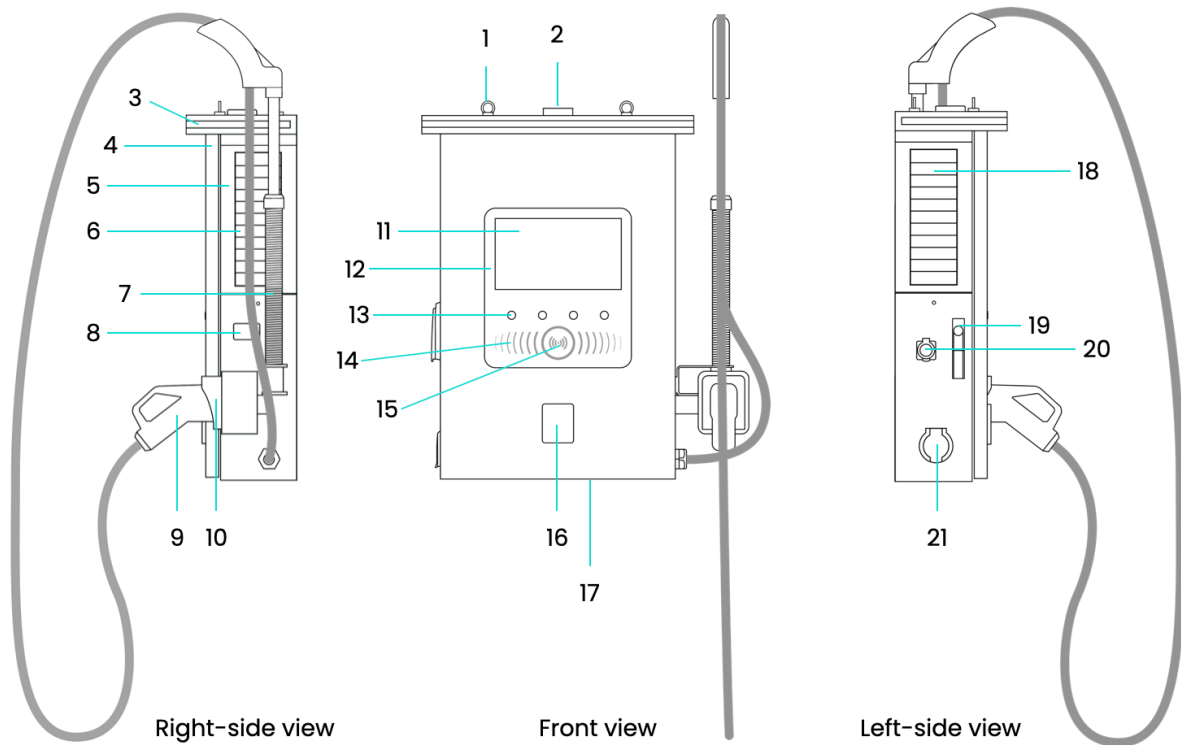

- |                              |                                 |
|------------------------------|---------------------------------|
| 1. Eye bolt                  | 12. Tampered glass              |
| 2. Antenna                   | 13. Buttons                     |
| 3. HALO rooftop lighting     | 14. Charging wave LED indicator |
| 4. Front cabinet door        | 15. RFID card reader            |
| 5. Main cabinet              | 16. Payment terminal (optional) |
| 6. Right-side air outlet     | 17. Bottom air inlet            |
| 7. Spring CMS                | 18. Left air inlet              |
| 8. Meter transparency window | 19. Handle lock                 |
| 9. CCS2 connector            | 20. TE Socket (optional)        |
| 10. Holster                  | 21. Type 2 socket (optional)    |
| 11. 15.6-inch HD displays    |                                 |

**1.3.2 Inside View**

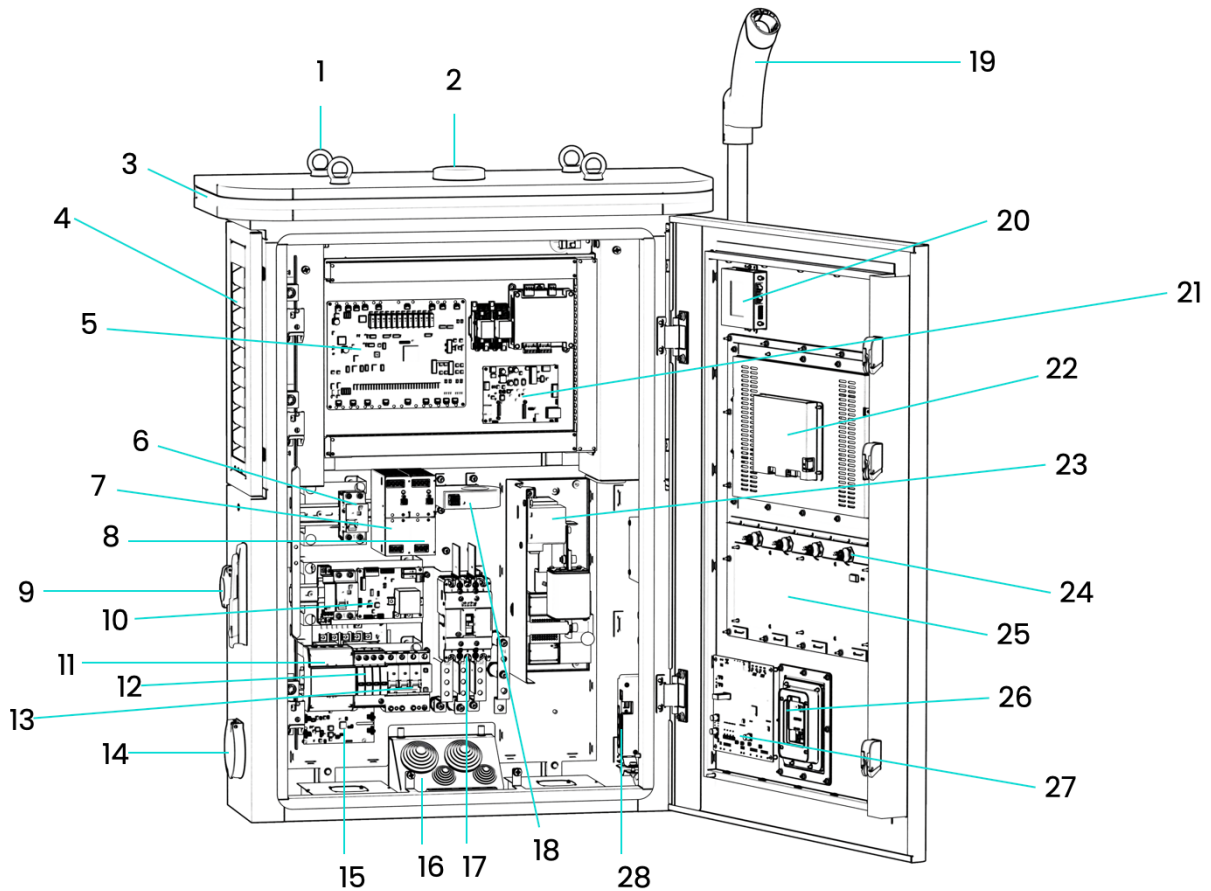

- |                              |                                 |
|------------------------------|---------------------------------|
| 1. Eye bolt                  | 15. AC 22kW control (optional)  |
| 2. Antenna                   | 16. Cable entry plate           |
| 3. HALO rooftop lighting     | 17. MCCB                        |
| 4. Left air inlet            | 18. Type B RCM                  |
| 5. CCU                       | 19. Spring CMS                  |
| 6. AUX protections           | 20. LTE router                  |
| 7. 24V DC PSU                | 21. SECC                        |
| 8. 12V DC PSU                | 22. HD display                  |
| 9. TE socket (optional)      | 23. Output unit                 |
| 10. TE control (optional)    | 24. Buttons                     |
| 11. AC 22kW RCBO (optional)  | 25. HMI board                   |
| 12. SPD                      | 26. Payment terminal (optional) |
| 13. MCB                      | 27. Gateway                     |
| 14. Type 2 socket (optional) | 28. TE block                    |

### 1.3.3 Cable Management System

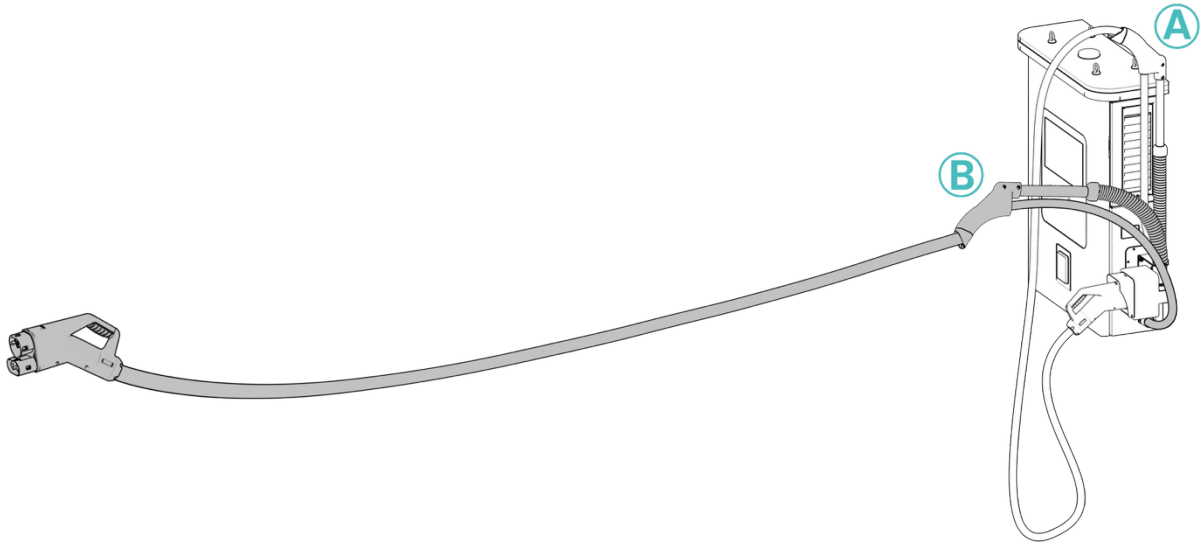

The spring cable management system enables smooth 360° rotation and up to 90° vertical articulation while maintaining a minimum 8× cable diameter bending radius for safe and durable cable movement.





Ref.	Part
A	CMS rest position
B	CMS extended position

**NOTE**

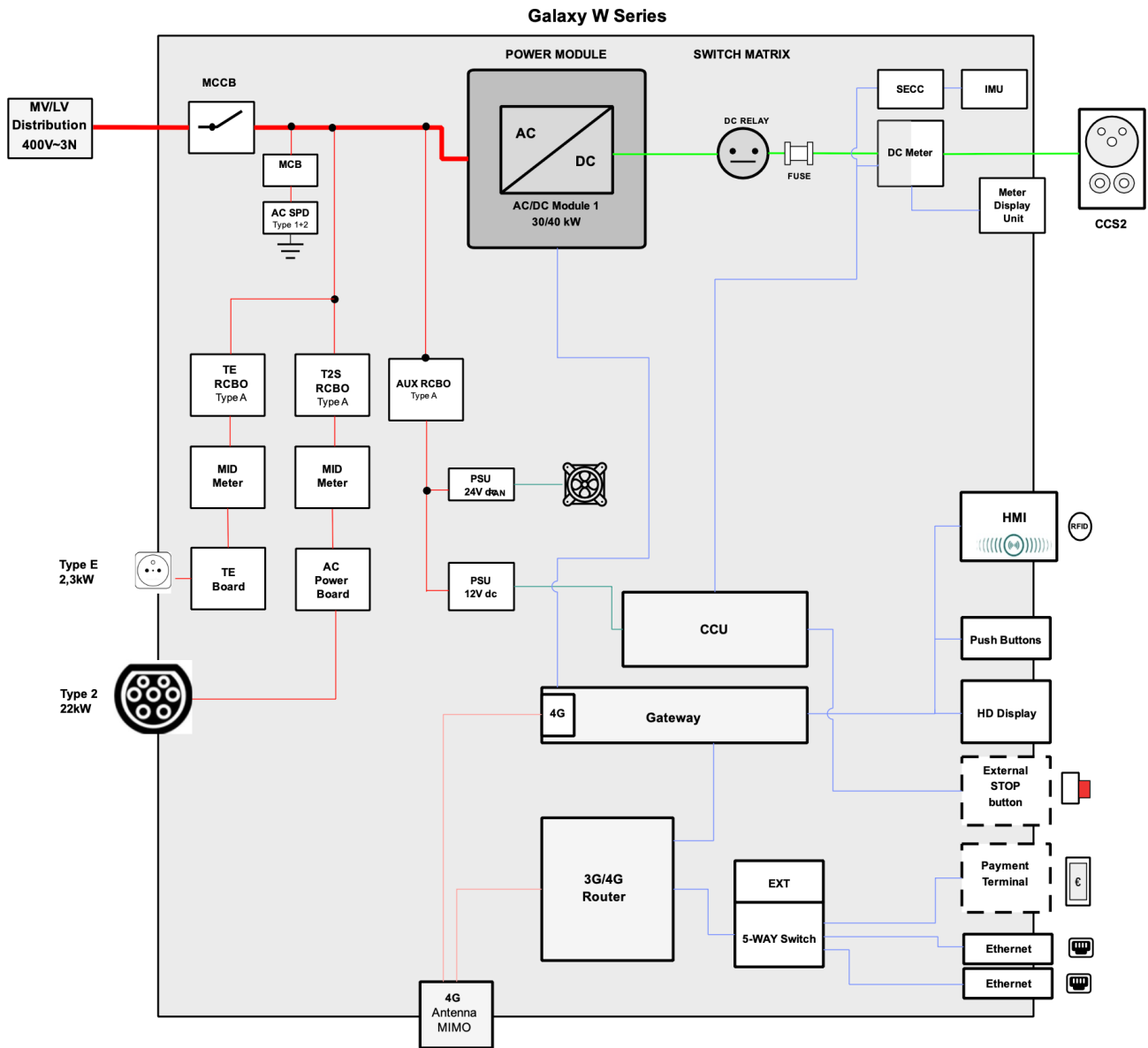



The illustration shows how the CMS of output 1 works. The same applies to the CMS of output 2.

### 1.3.4 Working Principal Diagram



Colours	Description
	AC power line
	DC power line
	Control signal communication
	Antenna

## 1.4 Symbols

Symbol	Description
	General risk
	Hazardous voltage, risk of electrocution
	WEEE – waste from electrical and electronic equipment
	Hot surface, risk of burn injuries

## 1.5 Terminology

Term	Description
<b>AC</b>	Alternating Current
<b>CCS</b>	Combined Charging System: An international standard for DC fast charging connectors and communication protocols.
<b>CCU</b>	Charging Control Unit: The main controller responsible for managing communication with the vehicle's Battery Management System (BMS) and regulating power output during charging.
<b>DC</b>	Direct Current
<b>EV</b>	Electric Vehicle
<b>IMD</b>	Insulation Monitoring Device: A safety device in DC charging systems that continuously monitors insulation resistance between live conductors and protective earth to detect leakage faults at an early stage.
<b>MCB</b>	Miniature Circuit Breaker: A protective device designed to automatically disconnect a circuit in the event of overload or short circuit.
<b>MCCB</b>	Molded Case Circuit Breaker: A high-capacity circuit protection device with adjustable trip settings, used for main power distribution circuits.
<b>OCPP</b>	Open Charge Point Protocol: An open communication standard between charging stations and central management systems (CMS).
<b>PE</b>	Protective Earth: A grounding conductor used for electrical safety protection against electric shock.
<b>RCBO</b>	Residual Current Breaker with Overcurrent Protection: A device combining residual current protection and overload/short-circuit protection.
<b>RCD</b>	Residual Current Device: A safety device that automatically disconnects a circuit when leakage current to earth is detected.
<b>RFID</b>	Radio Frequency Identification: A contactless technology used for user authentication at the charging station.
<b>SECC</b>	Supply Equipment Communication Controller: The communication controller within the charging station that manages communication with the electric vehicle.
<b>SOC</b>	State of Charge: The remaining battery capacity of an electric vehicle, expressed as a percentage of its total capacity.
<b>SPD</b>	Surge Protection Device: A device designed to protect electrical systems from voltage spikes and transient surges on AC power lines.

## 2. Safety Information

### 2.1 Liability

---

The manufacturer declares compliance with applicable regulations. The manufacturer is not liable for damage resulting from: unprofessional handling, non-compliance with manual, power outages, dirt/foreign substances, corrosion, cyber security breaches, vermin, external faults, natural hazards, improper installation, operation outside design conditions, incorrect maintenance, or improper storage.

#### 2.1.1 Installation Engineer Qualifications

Engineers must be qualified per local regulations, familiar with the Galaxy W Series and its safe installation and comply with all local regulations and this manual.

#### 2.1.2 Responsibilities and Qualifications for Users

Operators must comply with laws, identify hazards, operate with protective devices, prepare emergency plans, and ensure sufficient workspace.

### 2.2 Precautions for Use

---

#### 2.2.1 Transportation

Wear PPE. Use approved hoisting/forklift equipment. Follow equipment safety instructions.

#### 2.2.2 Installation

Ensure no voltage on input cables before work. Use the correct wire gauges. Do not modify the internal electrical configuration. Protect cables from damage. Do not open covers in adverse weather. Connect to Protective Earth (PE). Comply with local rules.

#### 2.2.3 Operation

Do not use if damaged, after a lightning strike, fire risk, water ingress, or impact.

#### 2.2.4 Maintenance

Wear PPE. Ensure no voltage during cleaning/maintenance. Reinstall safety devices after work.

#### 2.2.5 Disposal

Dispose of according to local laws and the WEEE directive. Do not mix with household waste.

---

## 2.3 Personal Protective Equipment

---

Wear protective clothing, safety gloves, shoes, and glasses as necessary.

## 2.4 Cyber Security

---

The owner is responsible for establishing and maintaining appropriate measures (firewalls, authentication, encryption, antivirus) to protect against security breaches. RAEDIAN is not liable for damages related to data breaches or unauthorized access.

### 3. Preparation

#### 3.1 Before Installation

Ensure: site prepared, all parts/tools available, correct wiring and circuit protection, proper grounding, cellular signal > -90 dBm (or install repeater), sufficient space for forklift and personnel.

**CAUTION**

In thunderstorm-prone regions, install an additional surge protection device at the main service panel. Always check local codes.

**NOTE**

For Ethernet, ensure internet connection is available. Consider cable inlet diameter.

#### 3.2 Location Requirements

An installation site design is a prerequisite for determining conduit and wiring requirements from the panel to proposed parking spaces, as well as for measuring cellular signal strength and identifying suitable locations for any necessary cellular signal booster equipment.

Find a suitable location to ensure normal operation and proper airflow around the unit. The space is calculated as follows:

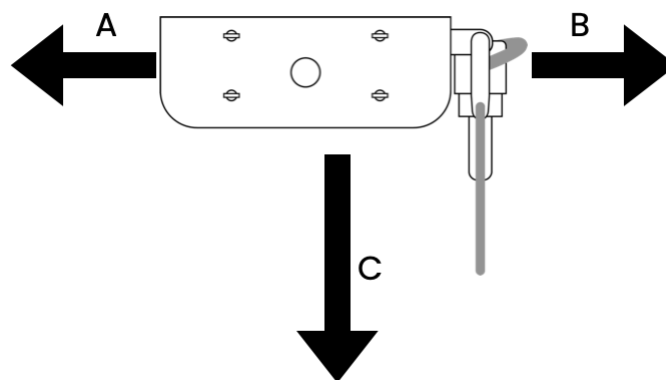

Parameter	Description	Specifications
A	Space to the left side	>500 mm
B	Space to the right side	>500 mm
C	Space to open the front door	>800 mm

The Galaxy W Series shall be installed in compliance with the applicable requirements of DIN 18040-1 for publicly accessible buildings.

### Wall Mounting Height

- The lower edge of the wall mounting bracket shall be installed at **700 mm ±10 mm AFFL** (Above Finished Floor Level).
- This mounting height ensures compliance with accessibility requirements for both standing and wheelchair users.

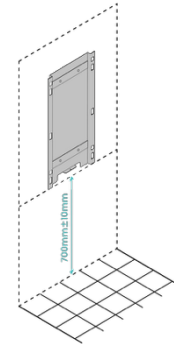

### User Interface Position

- The centre of all primary user interaction elements (display, RFID reader, payment terminal, if applicable) shall be positioned within: **850–1200 mm AFFL**
- This ensures an accessible reach range in accordance with the ergonomic principles of DIN 18040-1.

### Accessible Operating Space

- A clear and obstacle-free operating area of at least: **1500 mm × 1500 mm** shall be provided in front of the charger.
- The surface shall be level, stable, and suitable for wheelchair manoeuvring.

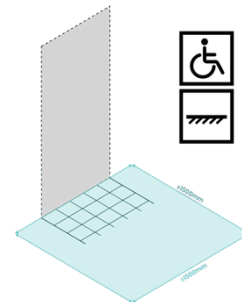

### Structural Requirements

- The wall structure shall be capable of supporting the charger weight and operational loads with an appropriate safety factor ( $\geq 1.5$ ).
- The mounting surface shall be verified prior to installation.

### Cable Routing

- Cable routing shall ensure compliance with the minimum bending radius requirements specified by the cable manufacturer.
- Adequate clearance shall be reserved for rear and bottom cable entry without obstruction.

Where national regulations impose stricter requirements than DIN 18040-1, the stricter requirements shall prevail.

### 3.3 Unpacking

#### 3.3.1 Forklift truck / Wheel loader pallet fork

Read and follow the operating and safety instructions labelled on the package. Use a forklift. Do not drop or tilt more than 30°. Avoid excessive force on hoisting points. Wear PPE.

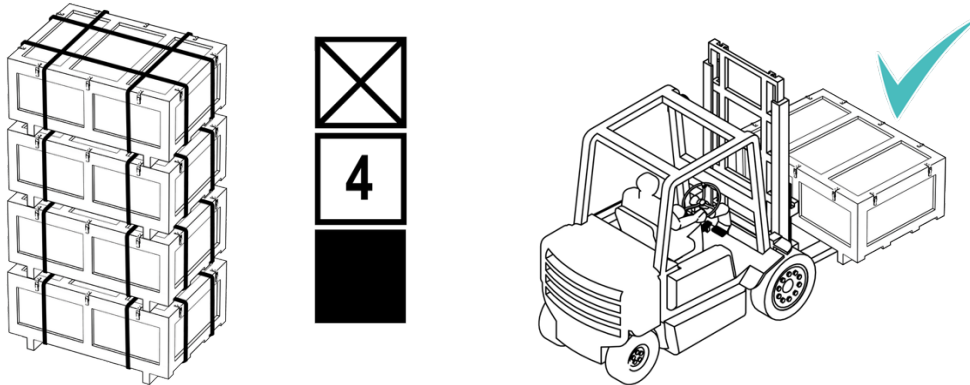

#### 3.3.2 Unpacking procedure

1. Cut and remove the plastic straps.

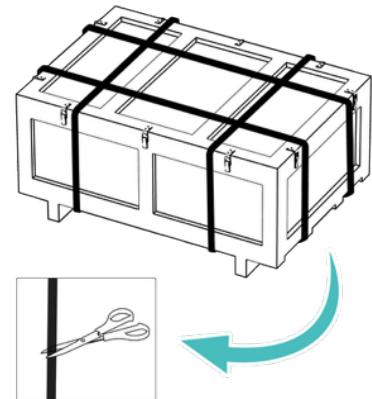

2. Remove the top cover and four cardboard walls

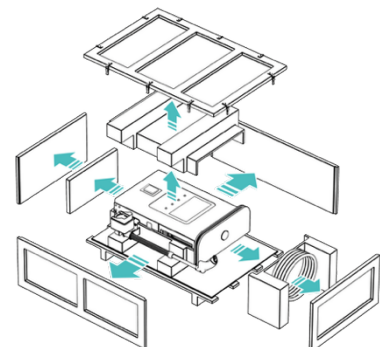



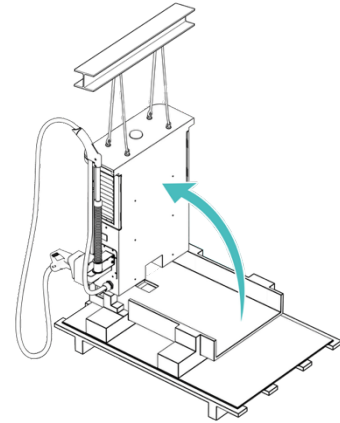





3. Use a crane or lifting equipment to hoist the charger and place it on a flat, stable surface near the installation site.



### 3.3.3 Packing List

When the Galaxy W Series is unpacked, make sure all components supplied are present:

<b>Galaxy W Series</b> × 1		<b>Expansion bolt (M12×200)</b> × 6	
<b>Cabinet door key</b> × 2		<b>Eye bolt (M12×20)</b> × 4	
<b>Bolt (M12×20)</b> × 4		<b>Packing list</b> × 1	
<b>Installation &amp; operation manual</b> × 1		<b>Admin badge</b> × 2	
<b>Lifting handle</b> × 2			

## 4. Installation

### CAUTION

Installation must be performed by an installation engineer. Obtain required permits. Ensure the AC input cable is available. Check voltages before powering-on. Ensure no voltage during installation.

### 4.1 Installing the Cabinet

#### 1. Secure the wall-mounted bracket

Position the wall-mounting bracket at the designated installation location and secure it to the wall using expansion bolts (M12×200). Ensure the bracket is level and firmly fixed before proceeding.

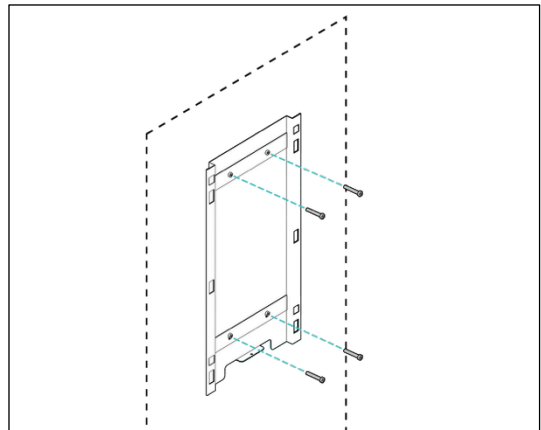

#### 2. Fit temporary lifting handles

Fit the temporary lifting handles to the left and right sides of the charger to make it easier to carry, and loosen the anti-theft screws at the bottom of the back panel.

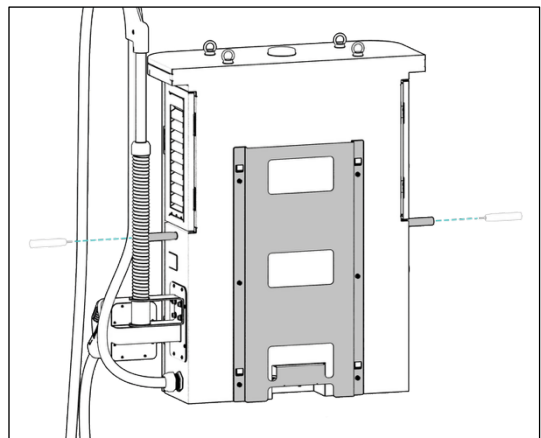

#### 3. Mount the charger onto the wall-mounted bracket

With two installers lifting the charger, align the charger mounting bracket with the wall-mounted bracket and carefully lower the charger into position.

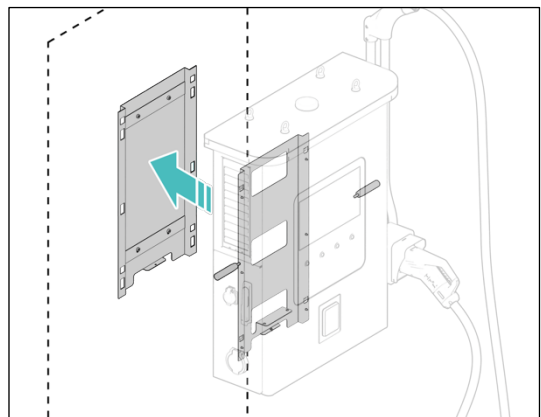

#### 4. Charger Secured

Install the charger on the wall, tighten the anti-theft screws, and remove the temporary handle.

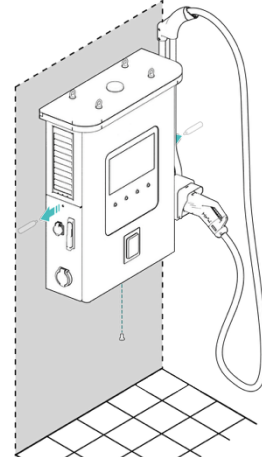

#### 5. Open the front door

Use the supplied key to unlock the door lock and open the front door.

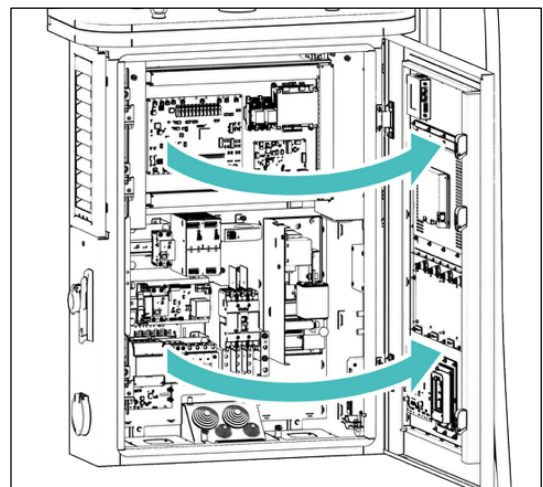

#### 6. Route the cables

Cut the stepped rubber grommets to match the cable diameters. Route the power cables and communication cables through the cable entry plate.

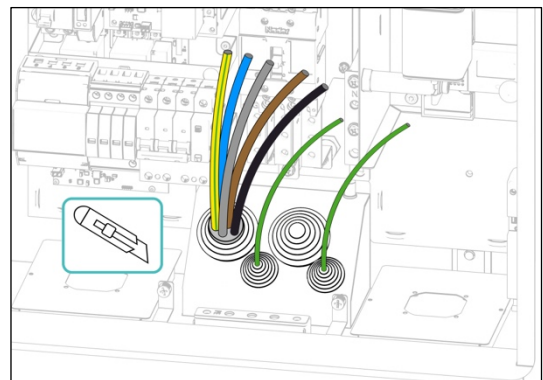

#### 7. Complete the wiring

Complete all electrical and communication cables.

- AC multicore cable (L1, L2, L3, N, and PE) (A)
- Ethernet upstream (B) & Ethernet downstream (C)

Verify all connections and seal the cable entry area with firestop putty or a suitable silicone-based sealant.

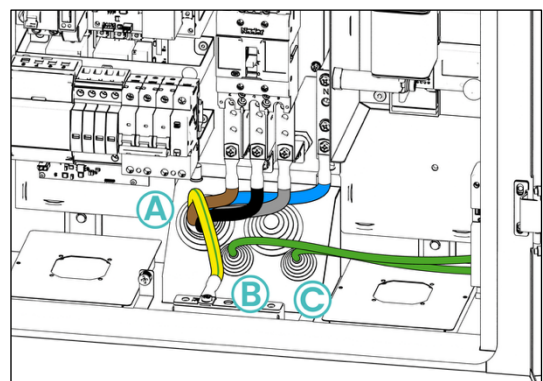

**8. Close the front door**

Close and secure the front door after all installation and wiring work has been completed.

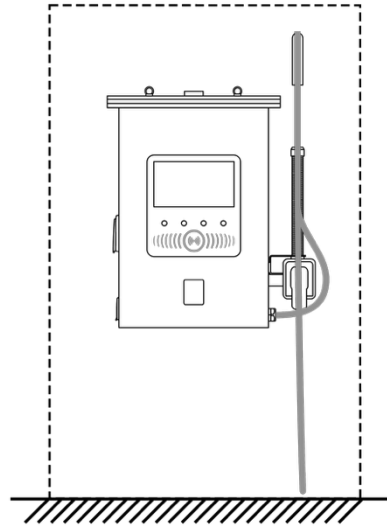
**9. Remove the eyebolts on the roof**

Remove all eyebolts from the roof of the charger and install the bolts (M12×20) into the mounting holes.

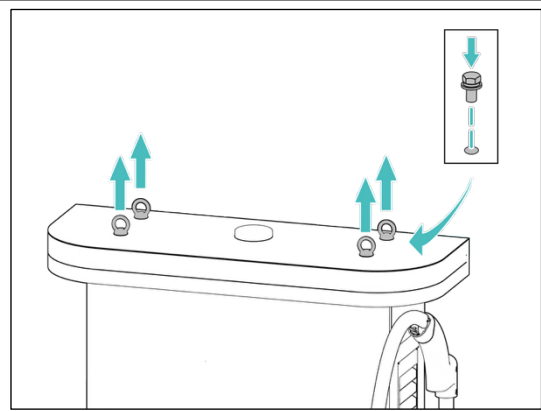

## 4.2 Electrical Wiring

### Protective Earth Connection

A protective earth (PE) connection is mandatory.

Before performing any operation, ensure that all external power supply switches are in the OFF position and verify the absence of voltage on the AC conductors.

The RAEDIAN Galaxy W Series must be properly earthed through the connection points marked with the protective earth symbol. Use a protective earth conductor with an appropriate cross-sectional area suitable for the maximum prospective ground fault current of the system.

The protective earth connection shall be made via the internal PE busbar provided inside the equipment.

#### CAUTION

In accordance with applicable laws, regulations, and standards, the protective earth conductor shall have a minimum cross-sectional area equal to at least half that of the phase conductor. This requirement is valid only when the protective earth conductor is made of the same material as the phase conductors. If different conductor materials are used, the cross-sectional area of the protective earth conductor shall be selected to provide equivalent electrical conductivity.

#### 4.2.1 Connecting the PE Wire

Cut PE wire to reach PE busbar, strip 20 mm, crimp cable lug, attach with fastener, tighten to  $20.5 \pm 2.5$  Nm.

#### 4.2.2 Connecting the Enclosure to Earth

Connect the earthing conductor from the enclosure pin to the earthing electrode.

#### 4.2.3 Connecting the AC Input Wire

Cut N, L1, L2, L3 to length, strip, crimp lugs, attach to AC fuse copper busbar (L1→A, L2→B, L3→C, N→D). Tighten to  $20.5 \pm 2.5$  Nm. Use cable ties. Seal conduit opening.

#### 4.2.4 Connecting the Ethernet Wire

Plug the Ethernet cable into the RJ45 port.

#### 4.2.5 Installing SIM Card

Press the button to eject the tray and insert the SIM card correctly.

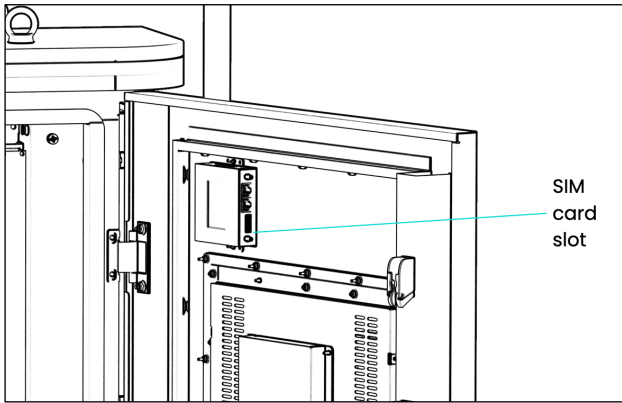

### 4.3 External AC Input Protections

The following schematic illustrates the typical position of external AC protection devices used in the installation.

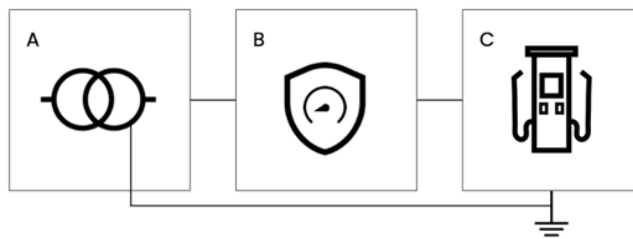

Parameter	Description
A	Medium voltage / Low voltage transformer
B	Low-voltage protection devices: <ul style="list-style-type: none"> <li>• Overcurrent protection</li> <li>• Residual Current Device (RCD)</li> <li>• Type I Surge Protection Device (SPD)</li> </ul>
<p><b>CAUTION</b> This information does not supersede any legal regulations. The installer should be aware that local regulations may impose requirements not reflected in this document. The most stringent requirements shall be applied.</p>	
C	EVSE

#### 4.3.1 Overcurrent protection

An external overcurrent protection device shall be installed on the AC supply line between the transformer and the EVSE.

The protection system may be implemented using one of the following configurations:

1. Main switch + 3 × 80 A fuses (gG or aG)
2. 3 × 80 A fuses (gG or aG)

### 3. 3-pole 80 A circuit breaker (thermal protection optional)

#### NOTE

In weak or unstable grid conditions, the AC input voltage may drop below the nominal value. Under these conditions, the EVSE may draw higher input current to maintain output power. This behaviour shall be considered when selecting and sizing the external overcurrent protection device.

The table below provides reference values for protection sizing

Parameter	Galaxy W Series
Rated AC input current	60 A @ 400 VAC
Maximum AC input current	60 A @ 360 VAC (-10%)
Maximum energy withstands short-circuit capability	0.9 MA <sup>2</sup> s

#### 4.3.2 Residual Current Device (RCD) Protection

##### DANGER – HAZARDOUS VOLTAGE

Where required by local electrical installation regulations, an external RCD shall be installed. The RCD shall be Type B/B+, with adjustable residual operating current ( $I_{\Delta n}$ ). In thunderstorm-prone regions, install an additional surge protection device at the main service panel. Always check local codes.

##### NOTE 1

Using an RCD with excessively low residual operating current may increase the risk of nuisance tripping, depending on the installation design and system configuration.

##### NOTE 2

In installations where multiple EVSE units are protected by a single RCD, adjustment of tripping current and tripping delay settings may be required to ensure selective coordination.

To reduce the risk of nuisance tripping, the RCD should meet the following recommendations:

RCD Specification	Galaxy W Series
Type	B / B+
Recommended sensitivity ( $I_{\Delta n}$ )	100 mA

## 4.4 Preparing for Commissioning

### CAUTION

Only a manufacturer-certified service engineer can commission the RAEDIAN's Galaxy W Series.

#### 4.4.1 Site readiness requirements

Before commissioning, ensure the following conditions are met:

- The RAEDIAN Galaxy W Series has been installed in accordance with this manual.
- AC input power is available at the installation site.

- Internet connectivity is available via one of the following methods:
  - Wi-Fi
  - Wired Ethernet connection
- At least one compatible EV is available for each connector type for functional testing.
- The site operator or owner is present to receive instructions from the manufacturer-certified service engineer during commissioning.

**4.4.2 Required information**

Ensure the following information is collected before commissioning:

- Site name and address
- Contact details of the on-site responsible person
- Specification of external protection devices (fuses or circuit breakers) in the distribution panel
- Installation completion date
- Photos of the charger and the surrounding installation environment
- Any special remarks or site-specific considerations

**4.4.3 Power energization support**

A responsible person must be present on site to assist in energizing the RAEDIAN Galaxy W Series from the distribution panel when required.

**4.4.4 Accessing the web configuration interface**

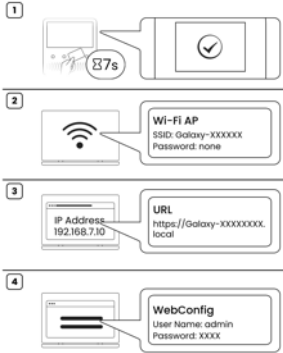
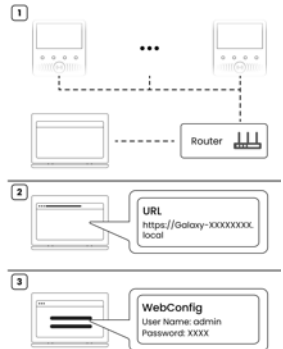
<p><b>Via Wi-Fi</b></p>	<ol style="list-style-type: none"> <li>1. Tap the service RFID card on the card reader for 7 seconds to activate the charger's built-in Wi-Fi hotspot.</li> <li>2. Connect the commissioning laptop to the charger's Wi-Fi network. The Wi-Fi SSID is provided on the product label.</li> <li>3. Enter the specified IP address in a web browser.</li> <li>4. Log in to the Web Configuration interface.</li> </ol>	
<p><b>Via Ethernet</b></p>	<ol style="list-style-type: none"> <li>1. Connect the commissioning laptop directly to the charger using an Ethernet cable.</li> <li>2. Enter the specified IP address in a web browser.</li> <li>3. Log in to the Web Configuration interface.</li> </ol>	

## 5. Operation

### 5.1 Before Use

Before operating the charger, ensure that the following conditions are met:

1. Verify that the charger is securely installed and fixed according to the installation requirements.
2. Ensure that the incoming power supply is connected correctly and that the rated input voltage is available.
3. Confirm that all protective devices, including MCCB, MCB, RCBO, SPD, and fuses, are in normal operating condition.
4. Check that the emergency stop button is released and not activated.
5. Verify that the display, communication modules, RFID reader, and payment terminal (if equipped) are functioning properly.
6. Ensure that the charging connector, cable assembly, and connector contacts are free from visible damage, deformation, or contamination.
7. Confirm that the ventilation openings are unobstructed and that adequate clearance is maintained around the charger.
8. Ensure that no alarm, fault, or warning message is displayed on the HMI before starting a charging session.
9. Verify that network communication is available when remote operation, payment services, or OCPP connectivity is required.
10. Make sure the charging area is dry, clean, and free from flammable, explosive, or corrosive materials.

## 5.2 Charging Procedure

### 5.2.1 Screen Layout



Parameter	Function	Description
1	Screen saver	Display promotional content on the home screen.
2	Help	View charger information and customer support details.
3	Language Selection	Switch the user interface language.
4	Tariff Information	View charging rates and pricing details.
5	Start Charging	Select the corresponding connector to begin charging.
6	4G Connection Status	Indicates the current 4G network connection status.
7	LAN Connection Status	Indicates the current LAN connection status.

When a connector is successfully plugged into your EV, the RAEDIAN Galaxy W Series automatically detects the connection and displays the corresponding authorization screen. If no action is taken for a certain period, the interface will automatically return to the home screen. Tap the corresponding button to enter the connector selection page, then select the connected connector to start charging.

**5.2.2 Authorization**

**NOTE**

Observe the screen for any abnormalities, such as an error message, before starting a charge session. Check the surroundings and the RAEDIAN's Galaxy W Series for any abnormalities or damage. If the screen displays an error message, DO NOT use the RAEDIAN's Galaxy W Series. Contact RAEDIAN Technical Support.

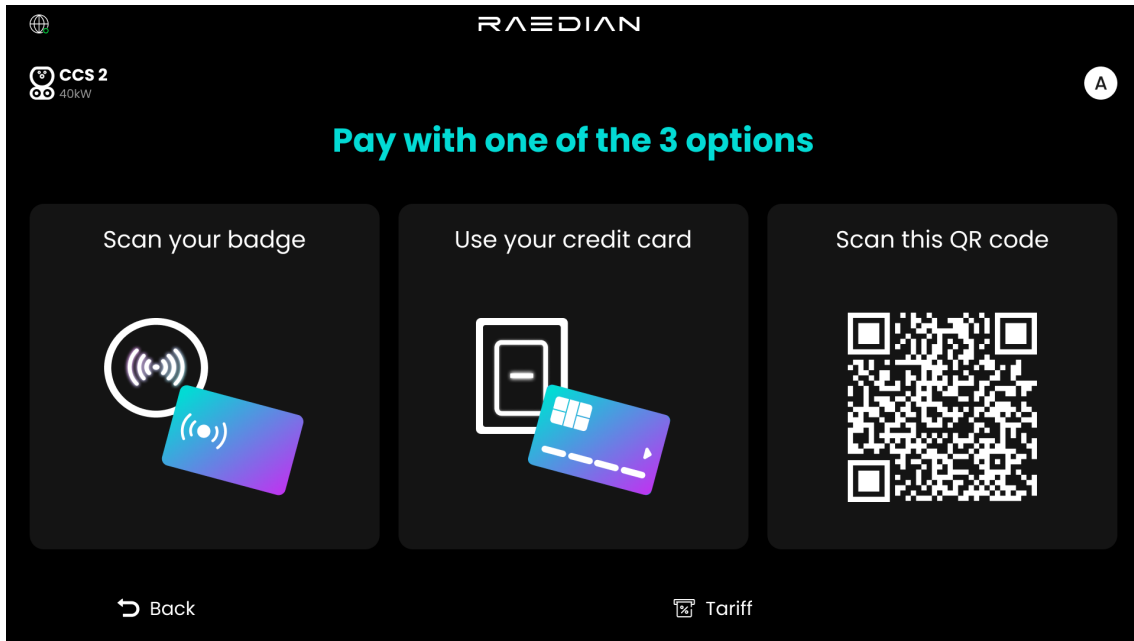

When the Authorization Screen appears, you can start charging using an RFID card, contactless payment card, or by scanning the QR code.

**5.2.3 Start Charging**

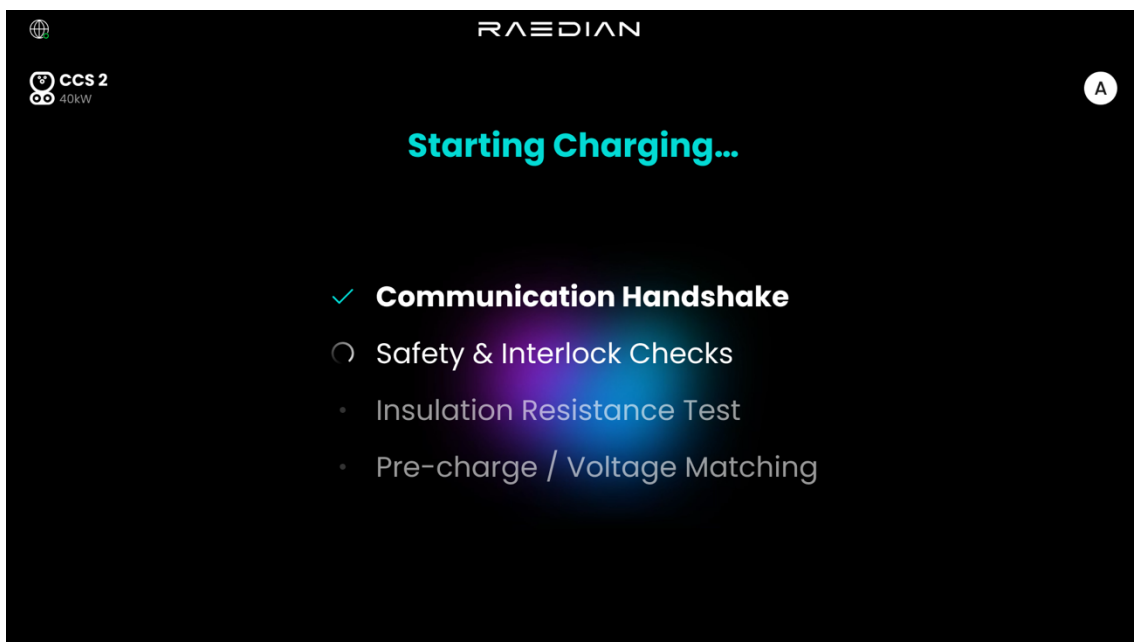

After authorization, communication and safety tests run automatically, then charging starts.

### 5.2.4 Charging

**NOTE**

The charging time to 80% is for reference only; the actual charging time depends on EV.

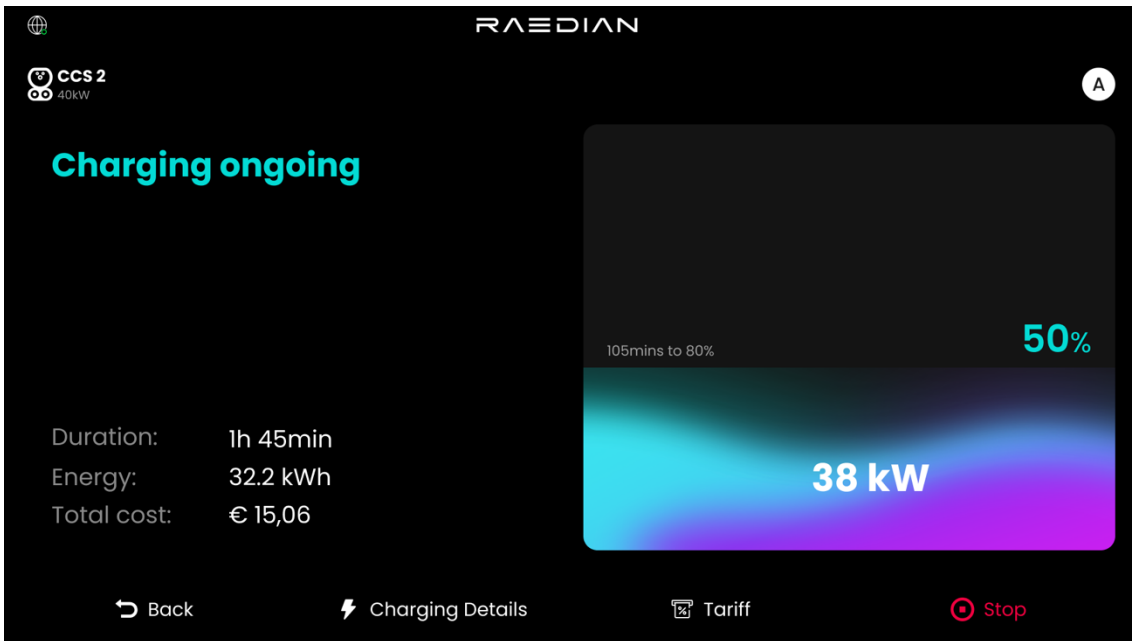

The screen shows duration, volume, cost, and power. Tap Stop to end the session.

### 5.2.5 Stop Charging

**NOTE**

Charging will stop automatically once the target state of charge (SOC) set by user is reached.

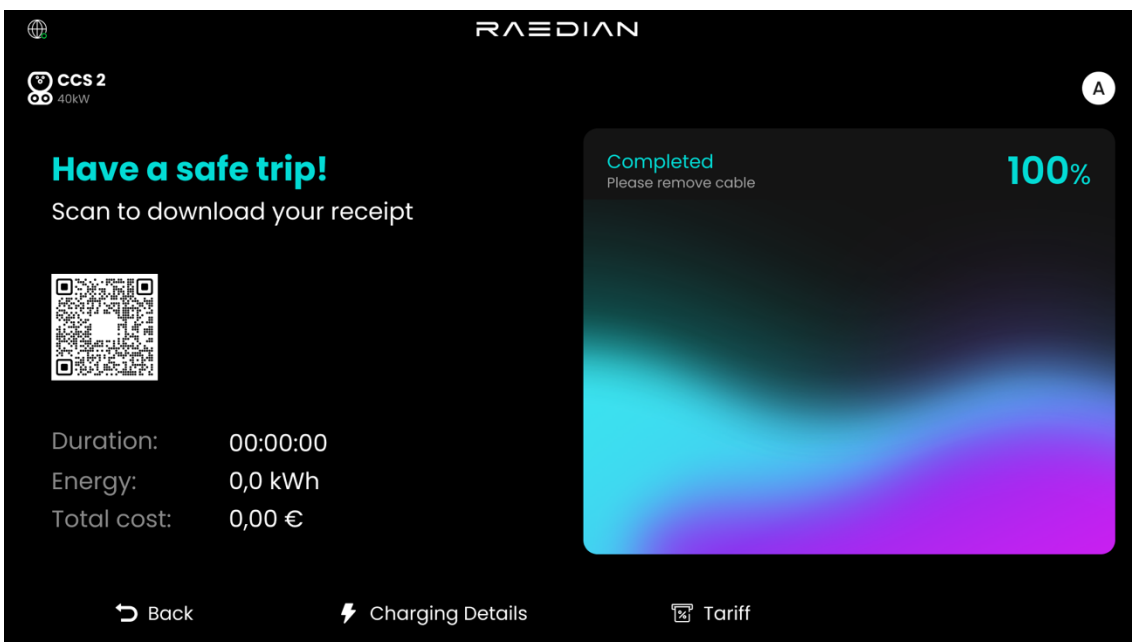

Tap Stop, then present RFID card again (if required). Disconnect cable and return to holster.

### **5.2.6 Finish Charging**

Return the connector to holster.

## **5.3 Charging Errors**

---

Connector connection error, authorization failed, start failure, charging failure – follow on-screen instructions. If persistent, contact support.

## **5.4 Energizing the Galaxy W Series**

---

Close the front door, set the upstream breaker to ON.

## **5.5 De-energizing the Galaxy W Series**

---

Set upstream breaker OFF and lock. Open door. Measure AC and DC voltage – ensure 0 V. Close door.

### **5.5.1 Measuring AC Voltage**

Measure between L1-L2, L1-L3, L2-L3, and N to each line on the SPD switch.

### **5.5.2 Measuring DC Voltage**

Remove insulating barrier, measure between power module outputs and EV cable outputs – must be 0 V.

## 6. Maintenance

The Galaxy W Series is designed for minimal maintenance. To ensure safe operation and optimal performance, periodic inspections should be performed by qualified personnel.

Disconnect the AC power supply before performing any maintenance work.

### CAUTION

Risk of electric shock. Only qualified electricians are permitted to remove covers or access internal components.

### 6.1 Maintenance Schedule

To ensure safe and reliable operation, periodic maintenance shall be performed by qualified personnel.

Item	Inspection	Frequency
<b>Enclosure</b>	Check for damage, corrosion, water ingress, or vandalism	Every 6 months
<b>CCS2 connector</b>	Check for wear, contamination, overheating marks, or mechanical damage	Every 3 months
<b>Type 2 socket</b>	Check for dirt, moisture, corrosion, and mechanical damage	Every 3 months
<b>Type E socket</b>	Check for contamination and physical damage	Every 3 months
<b>Cable glands and seals</b>	Check integrity and IP protection	Every 6 months
<b>Cooling fan and ventilation openings</b>	Remove dust and debris	Every 6 months
<b>Emergency stop button</b>	Verify correct operation and reset function	Every 6 months
<b>Protective devices</b>	Verify MCCB, RCBOs and SPD status indicators	Every 6 months
<b>Grounding connection</b>	Verify mechanical tightness and continuity	Annually
<b>Firmware and configuration</b>	Check for available updates	Annually

### 6.2 Cleaning

Before cleaning:

1. Stop all charging sessions.
2. Disconnect the charger from the power supply.
3. Wait for internal capacitors to discharge.

Cleaning instructions:

- Use a soft dry cloth.
- Use a damp cloth for stubborn dirt.

- 
- Do not use solvents or abrasive cleaners.
  - Do not use pressure washers.
  - Do not allow liquids to enter the enclosure.

### **6.3 Preventive Maintenance**

---

Qualified service personnel should periodically:

- Check the insulation condition of power circuits.
- Verify the correct operation of DC contactors and relays.
- Inspect fuse condition.
- Verify cooling fan operation.
- Confirm proper operation of SECC communication with electric vehicles.
- Update firmware and software when approved by the manufacturer.

## 7. Troubleshooting

The Galaxy W Series continuously monitors its internal systems. If a fault occurs:

1. Record the fault message displayed on the HMI.
2. Verify AC power supply availability.
3. Check external protection devices.
4. Restart the charger if permitted by local operating procedures.
5. Contact RAEDIAN technical support if the fault persists.

### 7.1 Troubleshooting Guide

Symptom	Possible Cause	Corrective Action
<b>Charger does not power on</b>	No AC input	Verify utility power supply
	MCCB open	Close MCCB after identifying cause
	Internal power supply fault	Contact service personnel
<b>Display remains off</b>	Display power loss	Check internal power supplies
	Communication fault	Restart charger
<b>Charger unavailable</b>	Emergency stop activated	Release and reset emergency stop
	Charger set to Out of Service	Check operating status
<b>CCS2 charging cannot start</b>	Vehicle connection incomplete	Reconnect CCS2 connector
	Authorization failed	Retry RFID, QR code or payment
	Vehicle rejects charging request	Verify vehicle status
<b>CCS2 charging stops unexpectedly</b>	Grid voltage abnormal	Verify incoming supply
	Overtemperature protection	Allow charger to cool
	Communication interruption	Retry charging session
<b>Type 2 charging cannot start</b>	Vehicle not connected correctly	Verify connector insertion
	RCBO tripped	Investigate cause and reset RCBO
<b>Type E socket unavailable</b>	RCBO tripped	Investigate cause and reset RCBO
	Auxiliary power fault	Contact service personnel
<b>RFID card not recognized</b>	Invalid RFID card	Use authorized card
	RFID reader fault	Restart charger
<b>Payment terminal unavailable</b>	Network communication failure	Verify network connection
	Payment terminal fault	Contact service provider
<b>Charger reports insulation fault</b>	Cable or vehicle insulation issue	Disconnect vehicle and retry
<b>Charger reports overcurrent fault</b>	Output short circuit or vehicle fault	Disconnect vehicle and inspect
<b>Charger reports SPD fault</b>	SPD end-of-life indication	Replace SPD module
<b>Charger reports meter fault</b>	MID meter communication failure	Contact service personnel
<b>Network offline</b>	Router or SIM issue	Verify network status
<b>OCPP connection lost</b>	Backend unavailable	Check backend platform status

## 7.3 Unsafe Operating Conditions

### CAUTION

Do not attempt to open the enclosure or repair internal components unless authorized and qualified to do so.

If any of the following conditions occur:

- Smoke, burning smell, or abnormal noise
- Electrical arcing
- Visible damage to the charger
- Water ingress into electrical compartments
- Repeated protection trips

Immediately:

1. Stop the charging session if it is still active.
2. Disconnect the charger from the upstream power supply.
3. Prevent further use of the charger.
4. Contact qualified service personnel for inspection and repair.

## 8. Specifications

### 8.1 General Specifications

Galaxy W Series	30kW	40kW
Input Rating	400VAC±10%, 50/60Hz, L1+L2+L3+N+PE	
Power Factor	≥0.99 @ full load	
Efficiency	≥96.7% @ full load (peak)	
Grid Type	TN-S, TN-C, TN-C-S, TT	
Output Interface	1× CCS2, 1× Type 2 Socket 22kW (optional), 1× Type E (optional)	
Output Power	CCS2: 30kW, Type 2 Socket: 22kW, Type E: 2.3kW	CCS2: 40kW, Type 2 Socket: 22kW, Type E: 2.3kW
Output Voltage	CCS2: 200-1000VDC, AC: 230/400VAC ±10%	
DC Output Current	Up to 100A	Up to 150A

### 8.2 User Interface

Display	15.6 inch
Support Language	EN/DE/FR/ES/IT/NL/PT (others on request)
HMI	270° RGB halo top lighting, RFID wave charging LED, 4×illuminated LED buttons
User Authentication	RFID badges (up to 500 local badges), dynamic QR code, App, contactless payment (optional)
RFID Reader	ISO/IEC 14443 A/B, ISO/IEC 18092, IEC/ISO 15693

### 8.3 Communication

Network Interface	Dual 4G LTE, Ethernet 10/100 Mbps
Protocol (EVSE & Backend)	OCPP 1.6J, OCPP 2.0.1/2.1 ready
Protocol (EVSE & EV)	DIN70121, ISO 15118-2/-20
Commissioning	WebConfig via LAN/WLAN
EMS Integration	Modbus TCP, RESTful API

### 8.4 Environmental

Operating Temperature	-30°C to +50°C (derating may apply)
Storage Temperature	-40°C to +70°C
Humidity	5% to 95% (non-condensing)
Altitude	≤2000m above sea level

## 8.5 Mechanical

<b>IP Rating</b>	IP55
<b>IK Rating</b>	IK10 (front housing), IK08 (tamper-resistant glass), IK07 (payment terminal)
<b>Cooling</b>	Forced-air cooling
<b>Charging Cable Length</b>	5m total cable length, 4.2m effective reach
<b>Cable Management System</b>	Spring (optional)
<b>Installation</b>	Wall/Ground/Trolley

## 8.6 Certification

<b>Standards &amp; compliance</b>	IEC 61851-1, IEC 61851-21-2, IEC 61851-23, LVD 2014/35/EU, RED 2014/53/EU, EN 18031
<b>Certification</b>	CE, Eichrecht (optional)

## Appendix A: Sticker instructions

### Log in to WebConfig and configure the charger

<p><b>1</b></p> <p>Diagram showing two chargers connected to a laptop and a router. Dashed lines indicate connections between the chargers, the laptop, and the router.</p>	<p><b>1</b></p> <p>Diagram showing a charger with a Wi-Fi symbol and a 7s timer. A callout box shows a checkmark in a square.</p>
<p><b>2</b></p> <p>Diagram showing a laptop screen with a callout box containing the URL: <code>https://Gemini-EC0U0DLR.local</code></p>	<p><b>2</b></p> <p>Diagram showing a Wi-Fi symbol and a callout box with the following details:  <b>Wi-Fi AP</b>          SSID: Gemini-0U0DLA          Password: none</p>
<p><b>3</b></p> <p>Diagram showing a laptop screen with a callout box containing the following details:  <b>WebConfig</b>          User Name: admin          Password: ECUU</p>	<p><b>3</b></p> <p>Diagram showing a laptop screen with two callout boxes. The first contains IP Address: 192.168.7.10. The second contains the URL: <code>https://Gemini-EC0U0DLR.local</code></p>
<p><b>3</b></p> <p>Diagram showing a laptop screen with a callout box containing the following details:  <b>WebConfig</b>          User Name: admin          Password: ECUU</p>	<p><b>4</b></p> <p>Diagram showing a laptop screen with a callout box containing the following details:  <b>WebConfig</b>          User Name: admin          Password: ECUU</p>

## ***Appendix B: Simplified EU Declaration of Conformity (DoC)***

**Manufacturer:** Zhejiang RAEDIAN New Energy Technology Co., Ltd.

**Address:** No. 3 Shuangbai Road, Yuanhua Town, Haining, Zhejiang, China

Zhejiang RAEDIAN New Energy Technology Co., Ltd. hereby declares that the radio equipment:

**Product:** DC EV Charging Station

**Model:** Galaxy W Series

is in compliance with Directive 2014/53/EU (Radio Equipment Directive), Directive 2014/30/EU (Electromagnetic Compatibility Directive), Directive 2014/35/EU (Low Voltage Directive), Directive 2011/65/EU (RoHS Directive), and other applicable EU legislation.

The full text of the EU Declaration of Conformity is available at the following internet address:

<https://www.raedian.com/support/downloads>